

## Serie Food & Drinks

### Raccordi automatici in PPSU CW510L

PPSU push-in fitting CW510L  
kunststoff steckverschraubungen CW510L  
Raccords instantanés en PPSU CW510L  
Racordaje automático en PPSU CW510L  
Conexões push-in em PPSU CW510L



New

#### Serie 53000

Pag. 5.7

### Raccordi automatici in PPSU INOX 316L

PPSU push-in fitting INOX 316L  
kunststoff steckverschraubungen INOX 316L  
Raccords instantanés en PPSU INOX 316L  
Racordaje automático en PPSU INOX 316L  
Conexões push-in em PPSU INOX 316L



New

#### Serie 53000X

Pag. 5.15

### Raccordi automatici a funzione, valvole a sfera, adattatori

Push-in fittings, function, ball valve, adapters  
Steckverschraubungen, funktionsverschraubungen, magnetventile,  
adapter  
Raccords instantanés, à fonctions, robinets à boisseau sphérique,  
adaptateurs  
Racordaje automático, a funciones, válvulas, accesorios  
Conexões push-in, funcionais válvulas de esfera, acessórios



#### Serie 59000

Pag. 5.24

### Raccordi automatici food grade

Food grade push-in fittings  
Steckverschraubungen lebensmittelkonform  
Raccords instantanés de qualité alimentaire  
Racordaje automático food grade  
Conexões push-in para indústria alimentícia



#### Serie 70000

Pag. 5.44

**RACCORDI AUTOMATICI, RACCORDI A FUNZIONE  
VALVOLE A SFERA, ADATTATORI**

*PUSH-IN FITTINGS, FUNCTION FITTINGS  
BALL VALVE, ADAPTERS*

*STECKVERSCHRAUBUNGEN, FUNKTIONSVERSCHRAUBUNGEN,  
MAGNETVENTILE, ADAPTER*

*RACCORDS INSTANTANÉS, RACCORDS À FONCTIONS  
OBINETS À BOISSEAU SPHÉRIQUE, ADAPTATEURS*

*RACORDAJE AUTOMÁTICO, RACORES A FUNCIONES  
VÁLVULAS, ACCESORIOS*

*CONEXÕES PUSH-IN, CONEXÕES FUNCIONAIS  
VÁLVULAS DE ESFERA, ACESSÓRIOS*



COMPONENT



**Serie 59000**

IT

Aignep con la serie 59.000, nel rispetto delle continua evoluzione normative del settore alimentare, propone una gamma di prodotti certificati NSF 169, nonché alla 1935/2004/CE ed alla DM 174.

Questa serie realizzata con ottone a basso tenore di piombo CW510L é la risposta attuale e disponibile per tutti i clienti che hanno questa nuova e crescente esigenza.

### Principali vantaggi

- NSF 169, 1935/2004/CE, DM 174
- Connessione e sconnessione istantanea
- Pieno passaggio e tenuta al vuoto grazie a guarnizioni sagomate
- Due tipologie di filettature, BSPP, BSPT
- Vasta gamma a disposizione per soddisfare le installazioni più esigenti
- Silicon Free

### Applicazioni

- Industria agroalimentare
- Macchine per caffè e vending
- Food & Beverage
- Medicaie
- Vuoto

GB

The 59,000 serie is the latest development in the Food&Beverage sector.

Fittings are certified NSF 169 standards and to the food norm 1935/2004/CE & Italian DM 174.

This line is made with a special Leadfree alloy CW510L.

### Main advantages

- NSF 169, 1935/2004/CE, DM 174
- Quick connection and disconnection
- Full Flow and Vacuum resistant tank to special shaped seals
- 2 threads available, BSPP, BSPT (universal short)
- Large range to comply food norms
- Silicon Free

### Applications

- Dairy
- Coffee Machines, Vending
- Food & Beverage
- Medical
- Vacuum

DE

Die 59.000 Serie ist die neueste Entwicklung im Lebensmittel & Getränke Sektor.

Die Verschraubungen sind zertifiziert NSF 169 Normen und zu der Lebensmittelnorm 1935/2004/CE & Italian DM 174.

Diese Serie wird mit einer speziellen bleifreien Legierung CW510L gemacht.

### Hauptvorteile

- NSF 169, 1935/2004/CE, DM 174
- Schnelle Verbindung und Trennung
- Voller Durchfluss und Vakuumfestigkeit, dank spezieller Formdichtungen
- Zwei Gewindearten, BSPP und BSPT
- Grosses Sortiment, welches die Lebensmittel-Normen erfüllt
- Silikonfrei

### Anwendungen

- Milchprodukte
- Kaffeemaschinen und Automaten
- Lebensmittel & Getränke
- Pharmaindustrie
- Vakuum

FR

La série 59000 est le dernier développement spécifique pour le secteur Alimentaire & boisson.

Les raccords sont certifiés NFS 169 à la norme alimentaire 1935/2004 / CE et Italienne DM 174.

Cette gamme est conçue avec un laiton CW510L.

### Principaux avantages

- NSF 169, 1935/2004 / CE, DM 174
- Connexion et déconnexion instantanée
- Plein débit et tenue au vide grâce à des joints de forme
- 2 filetages disponibles, BSPP, BSPT
- Large gamme pour répondre aux normes alimentaires
- Sans Silicone

### Applications

- Industries agroalimentaire
- Machines à café
- Distributeurs de boisson
- Médical
- Vide

ES

Aignep con la serie 59.000 Foods & Drinks, de acuerdo con la evolución de las normas cambiantes de la industria alimentaria, propone una gama de productos certificado NFS 169, así como la 1935/2004/CE y la DM 174.

Esta serie realizada en latón con bajo nivel de plomo CW510L es la respuesta actual y disponible para todos los clientes que tengan esta nueva y creciente exigencia.

### Principales ventajas

- NSF 169, 1935/2004 / CE, DM 174
- Conexión y desconexión instantánea
- Paso total y estanqueidad al vacío gracias a las juntas moldeadas
- Dos tipos de roscas, BSPP, BSPT
- Amplia gama disponible para satisfacerlas instalaciones más exigentes
- Libre de silicona

### Aplicaciones

- Industria agroalimentaria
- Maquinas de café y vending
- Alimentos y bebidas
- Medical
- Vacío

PT

A série 59.000 é o mais recente desenvolvimento da Aignep para o segmento de Alimentos e Bebidas. As conexões são fabricadas certificados NFS 169 com a norma 1935/2004/CE e também da norma italiana DM 174.

Esta linha é feita com uma liga especial sem presença de chumbo CW510L.

### Principais vantagens

- NSF 169, 1935/2004/CE, DM 174
- Rápida conexão e desconexão.
- Vazão Total e resistência ao vácuo graças ao design de suas vedações
- 2 threads available, BSPP, Métrica
- Alta vazão para atender às normas alimentícias
- Livre de Silicone

### Aplicações

- Aplicações tradicionais
- Máquinas de café, vending machines
- Alimentícia e bebidas
- Médica
- Vácuo



**CARATTERISTICHE TECNICHE**

TECHNICAL CHARACTERISTICS  
TECHNISCHE ANGABEN  
CARACTÉRISTIQUES TECHNIQUES  
CARACTERÍSTICAS TÉCNICAS  
CARACTERÍSTICAS TÉCNICAS



**Norma di Riferimento**

Reference standard

Entspricht der Norm

Norme de référence

Normativa de referencia

Norma de referència

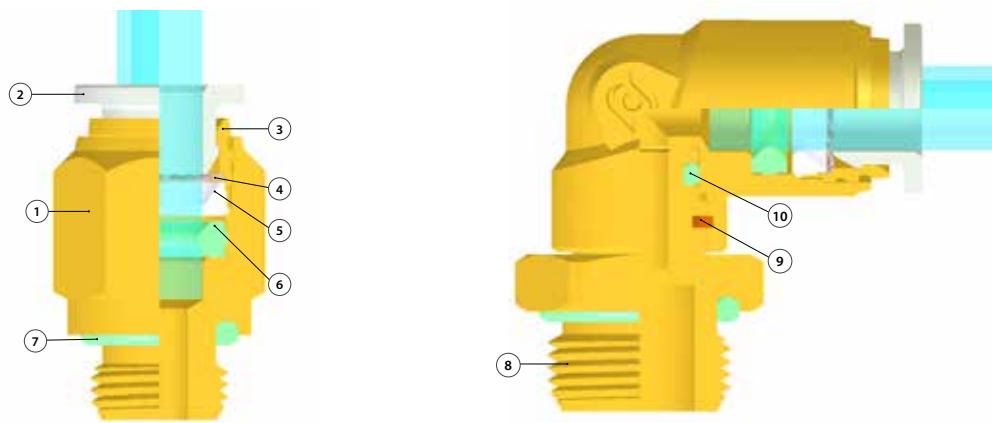

**Materiali e Componenti**

IT

- 1 Corpo in Ottone CW510L
- 2 Spintore sgancio tubo PPSU
- 3 Capsula in ottone CW510L
- 4 Pinza d'aggraffaggio in acciaio inox AISI 301
- 5 Anello di posizionamento PPSU
- 6 Guarnizione sagomata in FKM Alimentare
- 7 Guarnizione O-ring FKM Alimentare
- 8 Basetta filettata in ottone CW510L
- 9 Seeger
- 10 Guarnizione FKM Alimentare

**Component Parts and Materials**

GB

- 1 CW510L brass body
- 2 PPSU Collet
- 3 CW510L brass capsule
- 4 Steel AISI 301 clamping washer
- 5 PPSU positioning ring
- 6 Molded seal in FKM FOOD
- 7 O-Ring seal in FKM Food
- 8 CW510L brass base threaded
- 9 Seeger
- 10 Seal in FKM Food

**Komponenten und Materialien**

DE

- 1 Körper Messing CW510L
- 2 Druckring PPSU
- 3 Haltering Messing CW510L
- 4 Zahnscheibe Edelstahl AISI 301
- 5 Positionierring PPSU
- 6 Lippendichtung FKM lebensmittelkonform
- 7 O-Ringdichtung FKM lebensmittelkonform
- 8 Gewindebasis Messing CW510L
- 9 Seeger
- 10 Lippendichtung FKM lebensmittelkonform

**Matériaux et Composants**

FR

- 1 Corps en laiton CW510L
- 2 Bouton poussoir : PPSU
- 3 Capsule de retenue: laiton CW510L
- 4 Rondelle d'accrochage en inox AISI 301
- 5 Anneau de positionnement PPSU
- 6 Joint de forme en FKM qualité alimentaire
- 7 Joint O-ring FKM qualité alimentaire
- 8 Bague de sécurité en laiton CW510L
- 9 Seeger
- 10 Joint FKM qualité alimentaire

**Materialies y componentes**

ES

- 1 Cuerpo en latón CW510L
- 2 Anillo extracción tubo en PPSU
- 3 Cápsula en latón CW510L
- 4 Pinza de agarre en acero inox AISI 301
- 5 Anillo de posicionamiento en PPSU
- 6 Junta de forma en FKM alimentario
- 7 Junta tórica en FKM alimentario
- 8 Base roscada en latón CW510L
- 9 Seeger
- 10 Junta en FKM alimentaria

**Materialis e Componentes**

PT

- 1 Corpo em latão CW510L
- 2 Anilha de liberação de tubo em PPSU
- 3 Cápsula em latão CW510L
- 4 Pinça de travamento em aço inoxidável AISI 301
- 5 Anel de posicionamento em PPSU
- 6 Vedação moldada em FKM alimentício
- 7 Vedação o-ring em FKM alimentício
- 8 Base roscada em latão CW510L
- 9 Seeger
- 10 Vedação em FKM alimentício



**Pressioni**

Pressures

Druckbereich

Pressions

Presiones

Pressões

- 0.99 bar (-0.099 MPa)

20 bar (2.0 MPa)



**Temperature**

Temperatures

Temperatur

Températures

Temperaturas

Temperaturas

- 15 °C

+ 190 °C



**Fluidi compatibili**

Aria compressa / Vuoto / Acqua / Alimenti  
Vapore (Su richiesta in EPDM PX) Max 130°C.

**Fluids**

Compressed air / Vacuum / Water / Food  
Steam (On request in EPDM PX) Max 130°C.

**Geeignete Medien**

Druckluft / Vakuum / Wasser / Lebensmittel  
Dampf (Auf Anfrage in EPDM PX) Max 130°C.

**Fluides compatibles**

Air comprimé / Vide / Eau / Boissons  
Vapeur (Sur demande en EPDM PX) Max 130°C.

**Fluidos compatibles**

Aire comprimido / Vacío / Agua / Alimentos  
Vapor (bajo pedido en EPDM PX) Max 130°C.

**Fluidos compatíveis**

Ar comprimido / Vácuo / Água / Alimentos  
Vapor (A pedido em EPDM PX) Max 130°C.



<b>Tubi di Collegamento</b> <b>IT</b> Tubi in materiale plastico: PA6, PA11, PA12, Polietilene, *Poliuretano, PTFE, FEP. *Utilizzo da 90 a 98 Shore, per la massima prestazione è consigliato 98 Shore A.	<b>Connection Tubes</b> <b>GB</b> Plastic tubes: PA6, PA11, PA12, Polyethylene, *Polyurethane, PTFE, FEP. *Use from 90 to 98 Shore, for maximum performance is recommended 98 Shore A.	<b>Geeignete Rohre</b> <b>DE</b> Kunststoffrohre: PA6, PA11, PA 12, Polyethylene, *Polyurethan, PTFE, FEP. *Verwenden Sie 90 bis 98 Shore, für maximale Leistung wird 98 Shore A empfohlen.
<b>Tubes Conseillés</b> <b>FR</b> Tubes plastiques: PA6, PA11, PA12, Polyéthylène, *Polyuréthane, PTFE, FEP. *Utilisation de 90 à 98 Shore, pour une performance maximale recommandée 98 Shore A.	<b>Tubos de Conexión</b> <b>ES</b> Tubos en material plástico: PA6, PA11, PA 12, Polietileno, *Poliuretano, PTFE, FEP. *Uso de 90 a 98 Shore, para un máximo rendimiento se recomienda 98 Shore A.	<b>Tubos de Conexão</b> <b>PT</b> Tubos em material plástico: PA6, PA11, PA12, Polietileno, *Poliuretano, PTFE, FEP. *Uso de 90 a 98 Shore, para o desempenho máximo é recomendado 98 Shore A.



<b>Filettatura</b> <b>IT</b> Gas conica conforme ISO 7.1, BS 21, DIN 2999. Gas cilindrica conforme ISO 228 Classe A.	<b>Threads</b> <b>GB</b> Tapered gas in conformity with ISO7.1, BS 21, DIN 2999. Parallel gas in conformity with ISO 228 Class A.	<b>Gewindearten</b> <b>DE</b> Konisches Gewinde nach Norm ISO 7.1, BS 21, DIN 2999. Zylindrisches Gewinde nach Norm ISO 228 Classe A.
<b>Filetages</b> <b>FR</b> Filetage conique conforme: ISO7.1, BS 21, DIN 2999. Filetage cylindrique conforme: ISO 228 Classe A.	<b>Roscas</b> <b>ES</b> Gas cónica conforme ISO 7.1, BS 21, DIN 2999. Gas cilíndrica conforme ISO 228 Clase A.	<b>Roscas</b> <b>PT</b> Gas cônica conforme ISO 7.1, BS 21, DIN 2999. Gas paralela conforme ISO 228 Classe A.



**Coppia di serraggio**

- Torque specifications
- Angaben Drehmoment
- Couple de serrage
- Par de apriete
- Especificações de Torque



ISO 228

I valori di rottura possono variare in base all'articolo  
 Breaking values may vary according to the item  
 Die maximal werte dienen nur zu informationszwecken  
 Les valeurs maximales sont présentées à titre indicatif  
 Los valores de rotura pueden variar en función del artículo  
 Os valores de ruptura podem variar em função do item

MISURA MEASURE GRÖSSE DIMENSIONS MEDIDA MEDIDA	COPPIA CONSIGLIATA Nm RECOMMENDED TORQUE Nm EMPFOHLENES DREHMOMENT Nm COUPLE DE SERRAGE Nm PAR ACONSEJADO Nm TORQUE RECOMENDADO Nm
1/8	3
1/4	9
3/8	10



**Vantaggi**

**IT**

- 1 La pinza in acciaio inox garantisce il perfetto aggraffaggio di tubi di qualsiasi materiale senza danneggiarne la superficie. Il collegamento tra tubo e raccordo assicura una tenuta totale anche in condizioni di urti e vibrazioni.
- 2 La particolare geometria della guarnizione permette inoltre l'utilizzo dei raccordi anche con il vuoto.
- 3 Tutte le filettature di questa serie sono state dotate di elementi di tenuta che permettono l'immediato utilizzo dei raccordi riducendo notevolmente i tempi di installazione.
- 4 Raccordo orientabile con anello di sicurezza interno. Garantisce maggiore durata alla rotazione e trazione.

**Advantages**

**GB**

- 1 The washer is made in stainless steel ensures the perfect tube clamping with every kinds of materials without damage the surface. The connection between the tube and the fitting ensure a total tightness even in severe conditions such as impact and vibrations.
- 2 The particular geometric shape of the seal ensure the perfect tightness even with vacuum.
- 3 All of threads from this range have been equipped with tightening parts which allow the direct assembly of the fittings, reducing the installation time.
- 4 Orienting fitting with safety ring inside. Improved durability to the rotation and traction.

**Vorteile**

**DE**

- 1 Konisches Gewinde "kurz" Die Zahnscheibe sorgt für eine perfekte Halterung des Rohres ohne die Oberfläche zu beschädigen. Die Dichtheit zwischen Rohr und Verschraubung ist auch bei Erschütterungen und Vibrationen gewährleistet.
- 2 Die besondere Geometrie der Dichtung ermöglicht auch die Anwendung der Verschraubungen in Verbindung mit Vakuum.
- 3 Alle Verschraubungen in dieser Serie sind mit Gewindeabdichtungen ausgestattet, die den sofortigen Einsatz ermöglichen und daher die Montagezeit stark reduzieren.
- 4 Flexible Montage mit Sicherungsring innen. Verbesserte Beständigkeit gegenüber der Drehung und Traktions.

**Avantages**

**FR**

- 1 La rondelle en acier inoxydable garantit la parfaite tenue du tube quelle que soit la matière et sans l'endommager. La connexion entre le tube et le raccord assure une étanchéité totale même dans des conditions d'impact ou de vibrations.
- 2 La spécificité géométrique du joint permet l'utilisation des raccords avec le vide.
- 3 Tous les filetages de cette série sont équipés d'éléments d'étanchéité qui permettent l'utilisation immédiate des raccords réduisant ainsi le temps d'installation.
- 4 Accessoire de fixation réglable avec anneau de sécurité à l'intérieur. Amélioration de la durée de la rotation et de traction.

**Ventajas**

**ES**

- 1 La pinza en acero inoxidable garantiza el perfecto agarre del tubo de cualquier material sin perjudicar la superficie. La conexión entre tubo y racor asegura una estanqueidad total aun en condiciones de impacto o vibración.
- 2 La particular geometría de la junta garantiza una perfecta estanqueidad incluso en vacío.
- 3 Todas las rosas de esta serie están fabricadas con junta de cierre que permite la inmediata utilización del racor reduciendo notablemente el tiempo de instalación.
- 4 Montaje ajustable con sistema de seguridad interior. La mejora de la durabilidad a la rotación y tracción.

**Vantagens**

**PT**

- 1 A pinça em aço-inox garante o perfeito travamento do tubo de qualquer material sem danificar a superfície do mesmo. A conexão entre o tubo e a conexão assegura uma vedação total também em condições de impactos e vibrações.
- 2 A geometria particular da vedação permite a utilização da conexão também para aplicações com vácuo.
- 3 Todas as rosas desta série são dotadas de elementos de vedação, o que permite a imediata utilização das conexões, reduzindo notavelmente o tempo de instalação.
- 4 Montagem ajustável com anel de segurança dentro. A durabilidade melhorada para a rotação e tração.

## 59020

### RACCORDO DIRITTO MASCHIO CILINDRICO

STRAIGHT MALE ADAPTOR (PARALLEL)  
GERADE EINSCHRAUBVERSCHRAUBUNG ZYLINDRISCH  
RACCORD DROIT MÂLE, CYLINDRIQUE  
RACOR RECTO MACHO CILÍNDRICO CON TÓRICA  
CONEXÃO RETA COM ROSCA PARALELA



Code	Tube	A	B	L	CH	Pack.
59020 00 002	4	1/8	5.4	20	10	50
59020 00 003	6	1/8	5.4	23.5	13	50
59020 00 004	6	1/4	7.1	23.5	13	50
59020 00 005	8	1/8	5.4	25	14	50
59020 00 006	8	1/4	7.1	22.5	14	50

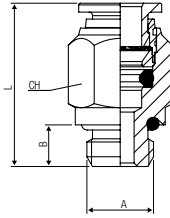

## 59030

### RACCORDO DIRITTO FEMMINA

STRAIGHT FEMALE ADAPTOR  
AUFSCHRAUBVERSCHRAUBUNG  
RACCORD DROIT, TARAUDE  
RACOR RECTO HEMBRA  
CONEXÃO RETA COM ROSCA FÊMEA



Code	Tube	A	B	L	CH	Pack.
59030 00 001	4	1/8	8.5	23.5	13	50
59030 00 002	6	1/8	8.5	25	13	50
59030 00 003	6	1/4	11	29.5	16	50
59030 00 010	8	3/8	12	32	19	50

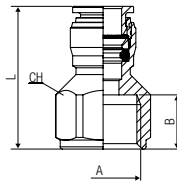

## 59040

### RACCORDO DIRITTO INTERMEDIO

STRAIGHT CONNECTOR  
VERBINDUNGSVERSCHRAUBUNG  
RACCORD UNION DOUBLE  
RACOR RECTO INTERMEDIO  
CONEXÃO RETA TUBO-TUBO



Code	Tube	A	B	L	CH1	Pack.
59040 00 001	4	28.5	10.5	50	10	50
59040 00 003	6	32.5	12.5	50	13	50
59040 00 005	8	35	14.5	50	13	50

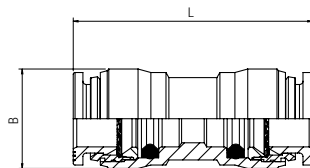

## 59100

### RACCORDO A L MASCHIO CONICO

ELBOW MALE ADAPTOR (TAPER)  
 WINKELVERSCHRAUBUNG KONISCH  
 EQUERRE MÂLE CONIQUE  
 RACOR A L MACHO CÔNICO  
 CONEXÃO MACHO EM "L" COM ROSCA MACHO CÔNICA



COMPONENT

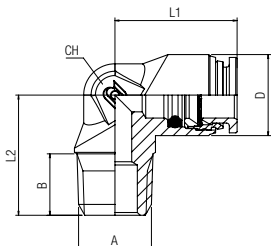

Code	Tube	A	B	L1	L2	CH	D	Pack.
59100 00 002	4	1/8	7.5	16.5	15.5	9	10	50
59100 00 003	6	1/8	7.5	20.5	17.5	11	12.5	50
59100 00 012	6	1/4	11	20.5	21.5	11	12.5	50
59100 00 005	8	1/4	11	21.5	22	13	14.5	50

## 59116

### RACCORDO A L ORIENTABILE MASCHIO CILINDRICO

ORIENTING ELBOW MALE ADAPTOR (PARALLEL)  
 WINKELVERSCHRAUBUNG ZYLINDRISCH (DREHBAR)  
 EQUERRE ORIENTABLE MÂLE, CYLINDRIQUE  
 RACOR A L ORIENTABLE MACHO CILÍNDRICO CON TÓRICA  
 CONEXÃO MACHO EM "L" ORIENTÁVEL COM ROSCA PARALELA



COMPONENT

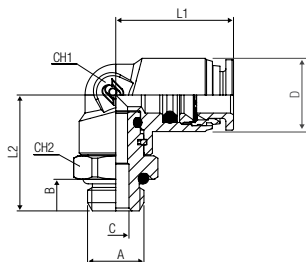

Code	Tube	A	B	C	L1	L2	CH1	CH2	D	Pack.
59116 00 003	4	1/8	5.4	4.5	17	18	9	13	10	50
59116 00 008	6	1/8	5.4	4.5	20.5	20	11	13	12.5	50
59116 00 009	6	1/4	7.1	4	20.5	21.5	11	16	12.5	50
59116 00 026	6	3/8	8.1	4	20.5	30	11	20	12.5	50
59116 00 011	8	1/4	7.1	6	22.5	23	12	16	12.5	50
59116 00 012	8	3/8	8.1	6	22.5	25	12	20	12.5	50

## 59130

### RACCORDO A L INTERMEDIO

ELBOW CONNECTOR  
 WINKELVERSCHRAUBUNG  
 RACCORD EQUERRE  
 RACOR A L INTERMEDIO  
 CONEXÃO EM "L" TUBO-TUBO



COMPONENT

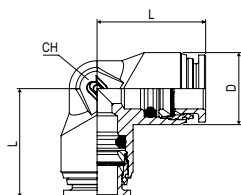

Code	Tube	L	CH	D	Pack.
59130 00 001	4	16.5	9	10	50
59130 00 002	6	20.5	11	12.5	50
59130 00 003	8	22	13	15	50

## 59216

### RACCORDO A T ORIENTABILE MASCHIO CILINDRICO

ORIENTING TEE MALE ADAPTOR (PARALLEL)-CENTRE LEG  
 T-EINSCHRAUBVERSCHRAUBUNG ZYLINDRISCH (DREHBAR)  
 TÉ ORIENTABLE À PIQUAGE MÂLE CENTRAL, CYLINDRIQUE  
 RACOR A T ORIENTABLE MACHO CENTRAL CILÍNDRICO CON TÓRICA  
 CONEXÃO EM "T" ORIENTÁVEL COM ROSCA MACHO PARALELA



Code	Tube	A	B	L1	L2	CH1	CH2	D	Pack.
59216 00 003	4	1/8	5.4	32.5	18.5	9	13	10	50
59216 00 008	6	1/8	5.4	40.5	21.5	11	13	12.5	50
59216 00 009	6	1/4	7.1	40.5	21.5	11	16	12.5	50
59216 00 011	8	1/4	7.1	44	24	13	16	14.5	50
59216 00 012	8	3/8	8.1	44	26	13	20	14.5	50

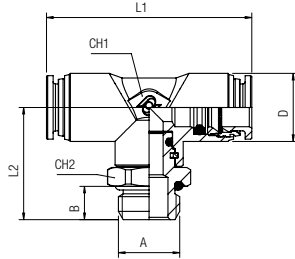

## 59226

### RACCORDO A T ORIENTABILE MASCHIO LATERALE CILINDRICO

ORIENTING TEE MALE ADAPTOR (PARALLEL) - OFF - SET LEG  
 L-EINSCHRAUBVERSCHRAUBUNG ZYLINDRISCH (DREHBAR)  
 TÉ ORIENTABLE À PIQUAGE LATÉRAL, CYLINDRIQUE  
 RACOR A T ORIENTABLE MACHO LATERAL CILÍNDRICO CON TÓRICA  
 CONEXÃO MACHO EM "T" LATERAL ORIENTÁVEL COM ROSCA PARALELA



Code	Tube	A	B	L1	L2	CH1	CH2	D	Pack.
59226 00 003	4	1/8	5.4	16.5	18.5	9	13	10	50
59226 00 008	6	1/8	5.4	20	20.5	11	13	12.5	50
59226 00 009	6	1/4	7.1	20	22	11	16	12.5	50
59226 00 011	8	1/4	7.1	22	23	13	16	14.5	50
59226 00 012	8	3/8	8.1	22	25	13	20	14.5	50

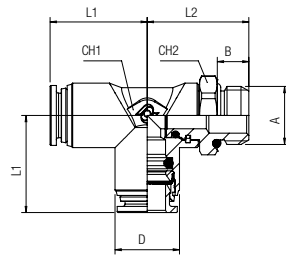

## 59230

### RACCORDO A T INTERMEDIO

TEE CONNECTOR  
 T-ANSCHLUSS  
 RACCORD TÉ  
 RACOR A T INTERMEDIO  
 CONEXÃO EM "T" TUBO-TUBO



Code	Tube	L1	L2	CH	D	Pack.
59230 00 001	4	32.5	16.5	9	10	50
59230 00 002	6	40.5	20.5	11	12.5	50
59230 00 003	8	44	22	13	14.5	50

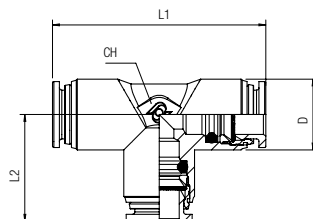

New

## VALVOLA UNIDIREZIONALE O DI NON RITORNO - CW510L

UNIDIRECTIONAL VALVES OR NON RETURN VALVES - CW510L  
 RÜCKSCHLAGVENTILE - CW510L  
 CLAPET ANTI-RETOUR - CW510L  
 VÁLVULAS UNIDIRECCIONALES O ANTIRETORNO - CW510L  
 VÁLVULAS UNIDIRECCIONAIS OU ANTI-RETOURNO - CW510L



### CARATTERISTICHE TECNICHE

TECHNICAL CHARACTERISTICS  
 TECHNISCHE ANGABEN  
 CARACTÉRISTIQUES TECHNIQUES  
 CARACTERÍSTICAS TÉCNICAS  
 CARACTERÍSTICAS TÉCNICAS



### Norma di Riferimento

Reference standard

Entspricht der Norm

Norme de référence

Normativa de referencia

Norma de referência

1907/2006  
 REACH ✓

2011/65/CE  
 RoHS ✓

M.O.C.A.  
 1935/2004  
 CE

PED  
 2014/68/UE

SILICON  
 FREE

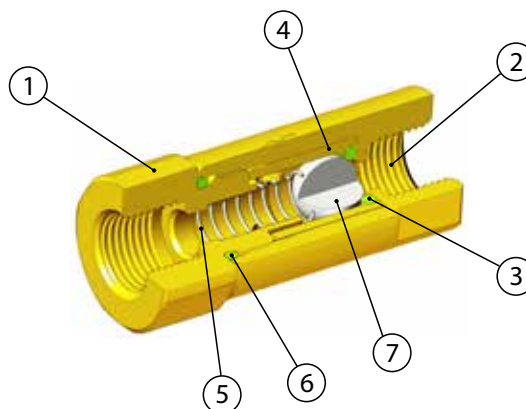
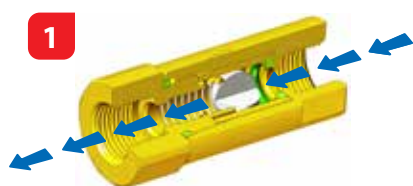

Materiali e Componenti	IT	Component Parts and Materials	GB	Komponenten und Materialien	DE
1 Corpo in Ottone CW510L		1 CW510L brass body		1 Körper Messing CW510L	
2 Attacco Terminale in ottone CW510L		2 CW510L Brass Valve Back Part		2 Ventilhinterteil Messing CW510L	
3 Guarnizione O-ring FKM Alimentare		3 O-Ring seal in FKM Food		3 O-Ringdichtung FKM lebensmittelkonform	
4 Bussola in ottone CW510L		4 CW510L Brass Compass		4 Kompass Messing CW510L	
5 Molla di mantenimento in acciaio AISI 302		5 Steel AISI 302 Keep spring		5 Feder Edelstahl AISI 302	
6 Guarnizione O-ring FKM Alimentare		6 O-Ring seal in FKM Food		6 O-Ringdichtung FKM lebensmittelkonform	
7 Sfera in acciaio AISI 420		7 AISI 420 steel ball		7 Kugel aus Stahl AISI 420	

Matériaux et Composants	FR	Materiales y Componentes	ES	Materiais e Componentes	PT
1 Corps en laiton CW510L		1 Cuerpo en latón CW510L		1 Corpo em latão CW510L	
2 Embase fileté: laiton CW510L		2 Parte posterior en latón CW510L		2 Parte traseira da válvula em Latão CW510L	
3 Joint O-ring FKM qualité alimentaire		3 Junta tórica en FKM alimentario		3 Vedação o-ring em FKM alimentício	
4 Boussole: Laiton CW510L		4 Brújula en latón CW510L		4 Bússola em Latão CW510L	
5 Ressort: acier inoxydable AISI 302		5 Muelle de mantenimiento en acero AISI 302		5 Mola de manutenção em aço AISI 302	
6 Joint O-ring FKM qualité alimentaire		6 Junta tórica en FKM alimentario		6 Vedação o-ring em FKM alimentício	
7 Bille en acier AISI 420		7 Bola de acero AISI 420		7 Esfera de aço AISI 420	



Filettatura	IT	Threads	GB	Gewindearten	DE
Gas cilindrica conforme ISO 228.		Parallel gas in conformity with ISO 228.		Zylindrisches Gewinde nach Norm ISO 228.	

Filetages	FR	Roscas	ES	Roscas	PT
Filetage cylindrique conforme: ISO 228.		Gas cilíndrica conforme ISO 228.		Gas paralela conforme ISO 228.	

IT

Questo tipo di valvole permette il libero passaggio in un solo senso (quello indicato dalla freccia) e lo impedisce nel senso contrario.

Azionate direttamente dall'aria che le attraversa, vengono normalmente impiegate come dispositivi di sicurezza, consentendo di mantenere in pressione una parte del circuito pur mandando a scarico l'alimentazione.

GB

This kind of valves allow the free passage in only one direction, the one showed with the arrow marked on the body. They do not allow the passage on the opposite way, i.e. non return.

They operate directly with the air that goes through, they are normally used as safety device, permitting to keep pressure in a part of the circuit, also when the feeding pressure has been taked off.

DE

Diese Art von Ventilen ermöglicht einen freien Durchgang in einer Richtung (wie durch den Pfeil angedeutet) und blockiert den Durchfluss des Mediums in die Gegenrichtung. Bei Druckabfall unter die durch eine Feder festgelegte Ansprechgrenze sperrt eine Verschlusskappe den Durchgang ab.

Kompakt und platzsparend sind diese Rückschlagventile ein Sicherheitselement, das sich perfekt in den Kreislauf einfügt.

FR

Cette vanne permet le libre passage du fluide dans la direction marquée par la flèche indiquée sur le corps. Elle ne permet pas le passage en sens inverse. Elle est autonome et fonctionne directement avec le fluide qui la traverse.

Elle est régulièrement utilisée comme dispositif de sécurité, permettant de maintenir la pression dans une partie du circuit lorsque la pression d'alimentation est coupée.

ES

Este tipo de válvulas permiten el libre paso en un sólo sentido (indicado por la flecha en el cuerpo) y lo impide en el sentido contrario.

Accionadas directamente por el aire, vienen normalmente utilizadas como dispositivos de seguridad, consintiendo en mantener en presión una parte del circuito, incluso cuando no existe presión en la alimentación.

PT

Este tipo de válvulas permite a libertação da passagem em apenas um sentido (aquele indicado pela seta) e impedir o fluxo no sentido contrário.

Acionadas diretamente pelo ar que as atravessa, são normalmente aplicadas como dispositivos de segurança, permitindo a manutenção da pressão em uma parte do circuito mesmo quando a alimentação da pressão é retirada.



**Pressione Max**

- Max Pressures
- Max Druckbereich
- Pressions Max
- Presiones Max
- Pressões Max

**8 bar** (0.8 MPa)



**Pressione minima di chiusura garantita**

- Guaranteed minimum closing pressure
- Garantierter minimaler Schließdruck
- Pression de fermeture minimale garantie
- Presión mínima garantizada de cierre
- Pressão de fechamento mínima garantida

**2 bar** (0.2 MPa)



**Pressione indicativa apertura**

- Approximate opening pressure
- Öffnungsdruck
- Pression d'ouverture
- Presión indicativa de apertura
- Pressão de abertura aproximada

**0.2 bar** (0.02 MPa)



**Temperature**

- Temperatures
- Temperatur
- Températures
- Temperaturas
- Temperaturas

**- 15 °C**  
**+ 190 °C**



**Portata a scarico libero 6 bar**

- Exhaust Free flow rate 6 bar
- Fluss Kostenlose Auspuff 6 bar
- Débit échappement libre 6 bar
- Caudal escape Libre 6 bar
- Vazão descarga livre 6 bar

Ø 1/8	600 NI/min
Ø 1/4	625 NI/min



**Fluidi compatibili**

Aria compressa / Vuoto / Acqua / Alimenti

**Fluids**

Compressed air / Vacuum / Water / Food

**Geeignete Medien**

Druckluft / Vakuum / Wasser / Lebensmittel

**Fluides compatibles**

Air comprimé / Vide / Eau / Boissons

**Fluidos compatibles**

Aire comprimido / Vacío / Agua / Alimentos

**Fluidos compatíveis**

Ar comprimido / Vácuo / Água / Alimentos

# 6061



## VALVOLA UNIDIREZIONALE FEMMINA-FEMMINA

FEMALE-FEMALE NON RETURN VALVE  
 RÜCKSCHLAGVENTIL INNEN- / INNENGEWINDE  
 CLAPET ANTI-RETOUR, FEMELLE/FEMELLE  
 VÁVULA UNIDIRECCIONAL HEMBRA-HEMBRA  
 VÁLVULA UNIDIRECCIONAL FÊMEA-FÊMEA

Code	A	B	L	CH1	CH2	Pack.
06061 000 07 CW	1/8	8.5	41.5	17	14	25
06061 000 08 CW	1/4	11	48	20	17	25

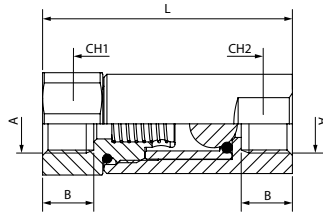

## VALVOLE A SFERA - CW510L

CW510L - BALL VALVES  
 KUGELHÄHNE - CW510L  
 ROBINET A BOISSEAU SPHERIQUE - CW510L  
 VÁLVULAS A ESFERA - CW510L  
 VÁLVULAS DE ESFERA - CW510L



### CARATTERISTICHE TECNICHE

TECHNICAL CHARACTERISTICS  
 TECHNISCHE ANGABEN  
 CARACTÉRISTIQUES TECHNIQUES  
 CARACTERÍSTICAS TÉCNICAS  
 CARACTERÍSTICAS TÉCNICAS

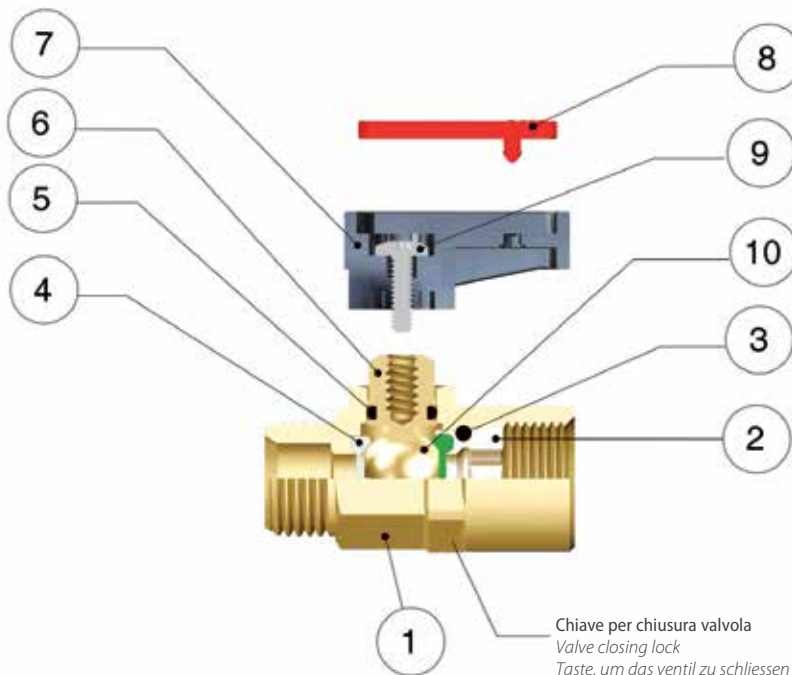

Chiave per chiusura valvola  
 Valve closing lock  
 Taste, um das Ventil zu schliessen  
 Clé pour vanne de fermeture  
 Llave para el cierre de la válvula  
 A chave para o fecho da válvula



### Norma di Riferimento

Reference Standard

Entspricht Der Norm

Conforme à La Norme

Normativa de Referencia

Norma de Referência

1907/2006

REACH ✓

2011/65/CE

RoHS ✓

M.O.C.A.

1935/2004

CE

PED  
2014/68/UE

SILICON  
FREE

### DIAGRAMMA PRESSIONE - TEMPERATURA

PRESSURE - TEMPERATURE RATINGS DIAGRAM

DRUCK - TEMPERATUR DIAGRAMM

DIAGRAMME PRESSION - TEMPÉRATURE

DIAGRAMA PRESIÓN-TEMPERATURA

DIAGRAMA DE PRESSÃO-TEMPERATURA

PTFE + FKM



### Temperature

Temperatures

Temperatur

Températures

Temperaturas

Temperaturas

FKM

- 15 °C

+ 130 °C

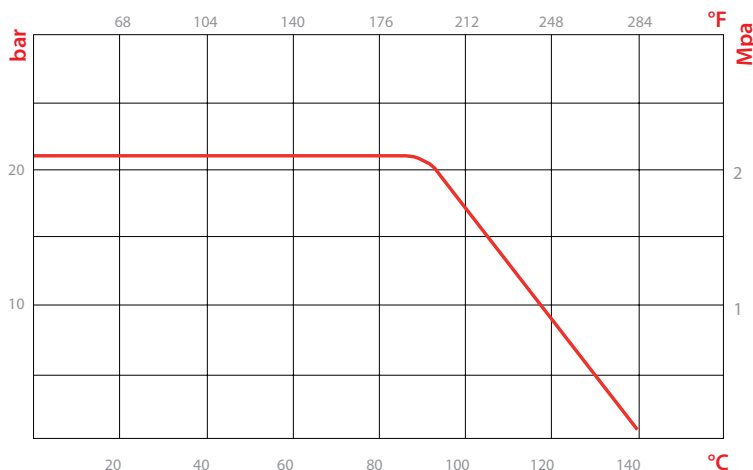



**Pressioni**

Pressures

Druckbereich

Pressions

Presiones

Pressões

**-0.99 bar** (-0.099 MPa)

**20 bar** (2 MPa)



**Fluidi compatibili**

Aria compressa / Vuoto / Acqua / Alimenti

Fluids

Compressed air / Vacuum / Water / Food

Geeignete Medien

Druckluft / Vakuum / Wasser / Lebensmittel

Fluides compatibles

Air comprimé / Vide / Eau / Boissons

Fluidos compatibles

Aire comprimido / Vacío / Agua / Alimentos

Fluidos compatíveis

Ar comprimido / Vácuo / Água / Alimentos

Materiali e Componenti	IT	Component Parts and Materials	GB	Komponenten und Materialien	DE
1 Corpo in Ottone CW510L		1 CW510L brass body		1 Körper Messing CW510L	
2 Ghiera o raccordo in Ottone CW510L		2 CW510L Brass Fitting		2 Gewindeinsatz Messing CW510L	
3 Guarnizione O-ring FKM Alimentare		3 O-Ring seal in FKM Food		3 O-Ringdichtung FKM lebensmittelkonform	
4 Guarnizione sede sfera in PTFE		4 PTFE Seats		4 Kugelsitzdichtung PTFE	
5 Guarnizione O-ring FKM Alimentare		5 O-Ring seal in FKM Food		5 O-Ringdichtung FKM lebensmittelkonform	
6 Albero in Ottone CW510L		6 CW510L Brass Spindle		6 Spindel Messing CW510L	
7 Maniglietta in PA66 Caricato vetro		7 PA66 Glass reinforced Handle		7 Handgriff PA66 Glasfaser verstärkt	
8 Piastrina in Resina Acetalica		8 Acetalic resin Plate		8 Griffplatte Acetal	
9 Vite in acciaio		9 Steel Screw		9 Schraube Stahl	
10 Sfera in Ottone CW510L		10 CW510L Nickel-plated Brass Ball		10 Kugel Messing CW510L	

Matériaux et Composants	FR	Materiales y Componentes	ES	Materiais e Componentes	PT
1 Corps en laiton CW510L		1 Cuerpo en latón CW510L		1 Corpo em latão CW510L	
2 Ecrou de blocage: laiton CW510L		2 Racor en latón CW510L		2 Conexões em Latão CW510L	
3 Joint O-ring FKM qualité alimentaire		3 Junta tórica en FKM alimentario		3 Vedação o-ring em FKM alimentício	
4 Joint bille sphérique: PTFE		4 Junta sede esfera en PTFE		4 Vedação da sede da esfera em PTFE	
5 Joint O-ring FKM qualité alimentaire		5 Junta tórica en FKM alimentario		5 Vedação o-ring em FKM alimentício	
6 Tige: laiton CW510L		6 Eje en latón CW510L		6 Eixo em Latão CW510L	
7 Poignée en PA66 chargé en fibre de verre		7 Maneta en PA66 con fibra de vidrio		7 Manopla em PA66 e fibra de vidro	
8 Plaquette de poignée: résine acétal		8 Plaqueta en PA6		8 Piaqueta de Resina Acetálica	
9 Vis: acier		9 Tornillo en acero		9 Parafuso em aço	
10 Bille: laiton CW510L		10 Esfera en latón CW510L		10 Esfera em Latão CW510L	



Filettatura	IT	Threads	GB	Gewindearten	DE
Gas conforme ISO 7.1, BS 21, DIN 2999		Gas in conformity with ISO7.1, BS 21, DIN 2999.		Gewinde nach Norm ISO 7.1, BS 21, DIN 2999.	
Filetages	FR	Roscas	ES	Roscas	PT
Filetage conforme: ISO7.1, BS 21, DIN 2999.		Gas conforme ISO 7.1, BS 21, DIN 2999		Gas conforme ISO 7.1, BS 21, DIN 2999.	

**6315**

**VALVOLA MASCHIO CONICO R ISO 7 - FEMMINA RP ISO 7**

TAPER MALE R ISO 7 - FEMALE RP ISO 7 VALVE  
 KUGELHAHN AUSSENGEW. KONISCH R ISO 7 - INNENGEW. RP ISO 7  
 ROBINET FILETAGE R ISO 7 - TARAUDAGE RP ISO 7  
 VÁLVULA MACHO CÔNICO R ISO 7 - HEMBRA RP ISO 7  
 VÁLVULA ROSCA MACHO CÔNICA R ISO 7 - ROSCA FÊMEA RP ISO 7



Code	A	B	DN	ES	F	M	L	G	H	Pack.
06315 000 01 CW	1/8	1/8	6	14-15	7.4	7.4	36	19	21	25
06315 000 03 CW	1/4	1/4	6	14-15	11	11	43	19	21	25

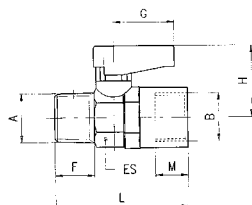

## REGOLATORE DI PORTATA ORIENTABILE - CW510L

CW510L - ORIENTING FLOW REGULATOR  
 DURCHFLUSSREGLER (DREHBAR) - CW510L  
 RÉGLEURS DE DÉBIT ORIENTABLES - CW510L  
 REGULADORES DE CAUDAL ORIENTABLES - CW510L  
 REGULADORAS DE VAZÃO ORIENTÁVELV - CW510L



## CARATTERISTICHE TECNICHE

TECHNICAL CHARACTERISTICS  
 TECHNISCHE ANGABEN  
 CARACTÉRISTIQUES TECHNIQUES  
 CARACTERÍSTICAS TÉCNICAS  
 CARACTERÍSTICAS TÉCNICAS



## Norma di Riferimento

Reference Standard

Entspricht Der Norm

Conforme à La Norme

Normativa de Referencia

Norma de Referência

1907/2006

REACH ✓

2011/65/CE

RoHS ✓

M.O.C.A.

1935/2004

CE

PED  
2014/68/UESILICON  
FREE

## Pressioni

Pressures

Druckbereich

Pressions

Presiones

Pressões



0.1 bar (0.01 MPa)

10 bar (1 MPa)



## Temperature

Temperatures

Temperatur

Températures

Temperaturas

Temperaturas

- 15 °C

+ 190 °C



## Fluidi compatibili

Aria compressa / Vuoto / Acqua / Alimenti

Fluids

Compressed air / Vacuum / Water / Food

Geeignete Medien

Druckluft / Vakuum / Wasser / Lebensmittel

Fluides compatibles

Air comprimé / Vide / Eau / Boissons

Fluidos compatibles

Aire comprimido / Vacío / Agua / Alimentos

Fluidos compatíveis

Ar comprimido / Vácuo / Água / Alimentos

## Materiali e Componenti

IT

- 1 Corpo in Ottone CW510L
- 2 Spillo di Regolazione in Ottone CW510L
- 3 Guarnizione O-ring FKM Alimentare

## Component Parts and Materials

GB

- 1 CW510L brass body
- 2 CW510L Brass Adjusting needle
- 3 O-Ring seal in FKM Food

## Komponenten und Materialien

DE

- 1 Körper Messing CW510L
- 2 Einstellnadel Messing CW510L
- 3 O-Ringdichtung FKM lebensmittelkonform

## Matériaux et Composants

FR

- 1 Corps en laiton CW510L
- 2 Vis de réglage: laiton CW510L
- 3 Joint O-ring FKM qualité alimentaire

## Materiales y componentes

ES

- 1 Cuerpo en latón CW510L
- 2 Tornillo de regulación en latón CW510L
- 3 Junta tórica en FKM alimentario

## Materiais e Componentes

PT

- 1 Corpo em latão CW510L
- 2 Agulha de Regulagem em Latão CW510L
- 3 Vedação o-ring em FKM alimentício



<b>Filettatura</b> Gas cilindrica conforme ISO 228 Classe A.	<b>IT</b>	<b>Threads</b> Parallel gas in conformity with ISO 228 Class A.	<b>GB</b>	<b>Gewindearten</b> Zylindrisches Gewinde nach Norm ISO 228 Classe A.	<b>DE</b>
<b>Filetages</b> Filetage cylindrique conforme: ISO 228 Class A.	<b>FR</b>	<b>Roscas</b> Gas cilíndrica conforme ISO 228 Clase A.	<b>ES</b>	<b>Roscas</b> Gas paralela conforme ISO 228 Classe A.	<b>PT</b>

## 6924

### REGOLATORE DI FLUSSO BIDIREZIONALE

BI-DIRECTIONAL FLOW REGULATOR  
 DURCHFLOSSREGLER BI-DIREKTIONAL  
 VIS RÉGLEUR DE DÉBIT BI-DIRECTIONNEL  
 TORNILLO REGULADOR BIDIRECCIONAL  
 REGULADORA DE VAZÃO BI-DIRECIONAL



Code	A	C	B	L1	L2	CH	D	Pack.
06924 000 02 CW	1/4	1/4	7.1	22	39	17	16.5	25

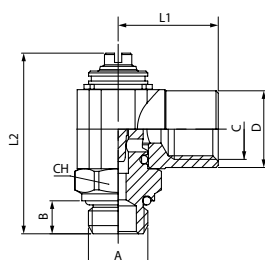

## RACCORDI FILETTATI - CW510L

CW510L - BRASS ADAPTORS  
 GEWINDEVERSCHRAUBUNGEN - CW510L  
 ACCESSOIRES DE RACCORDEMENT - CW510L  
 RACORDAJE ROSCADO - CW510L  
 ACESSÓRIOS ROSCADOS - CW510L



### CARATTERISTICHE TECNICHE

TECHNICAL CHARACTERISTICS  
 TECHNISCHE ANGABEN  
 CARACTÉRISTIQUES TECHNIQUES  
 CARACTERÍSTICAS TÉCNICAS  
 CARACTERÍSTICAS TÉCNICAS



### Norma di Riferimento

Reference standard

Entspricht der Norm

Norme de référence

Normativa de referencia

Norma de referência

1907/2006

REACH

2011/65/CE

RoHS

M.O.C.A.

1935/2004

CE

PED  
2014/68/UE

SILICON  
FREE

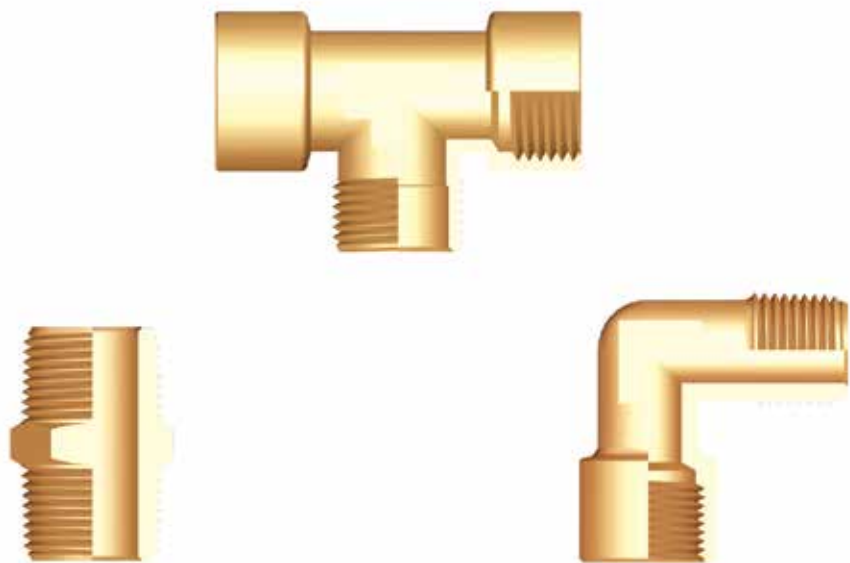

### Materiali e Componenti

IT

La maggior parte degli articoli di questa serie è composta da un unico particolare in CW 510L

### Component Parts and Materials

GB

The main part of these fittings is made in CW 510L

### Komponenten und Materialien

DE

Die meisten Artikel in dieser Serie werden aus CW 510L

### Matériaux et Composants

FR

La majeure partie des raccords de ce chapitre est fabriquée en laiton CW 510L

### Materiales y Componentes

ES

La mayor parte de los artículos de esta serie está compuesta de un solo material latón CW 510L

### Materiais e Componentes

PT

A maior parte dos itens desta série é fabricada em CW 510L



Misura  
Size  
Größe  
Dimensions  
Medida  
Tamanho

Pressione consigliata  
Pressure advised  
Empfohlener druck  
Empfohlener druck  
Pression conseillée  
Presión recomendada  
Pressão aconselhada

1/8

-0.99 bar ~ 150 bar

1/4

-0.99 bar ~ 100 bar



### Temperature massima

Maximum temperature

Maximum temperatur

Température maximale

Temperatura máxima

Temperatura máxima

+ 300 °C



**Fluidi compatibili**

Aria compressa / Vuoto / Acqua / Vapore / Alimenti

**Fluids**

Compressed air / Vacuum / Water / Steam / Food

**Geeignete Medien**

Druckluft / Vakuum / Wasser / Dampf / Lebensmittel

**Fluides compatibles**

Air comprimé / Vide / Eau / Vapeur / Boissons

**Fluidos compatibles**

Aire comprimido / Vacío / Agua / Vapor / Alimentos

**Fluidos compatíveis**

Ar comprimido / Vácuo / Água / Vapor / Alimentos



**Tubi di Collegamento**

Tubi e raccordi in genere.

IT

**Connection Tubes**

Tubes and fittings in general.

GB

**Geeignete Rohre**

Rohre und Verschraubungen im Allgemeinen.

DE

**Tubes Conseillés**

Raccords et tubes compatibles.

FR

**Tubos de Conexión**

Tubo y recordaje en general.

ES

**Tubos de Conexão**

Tubos e conexões em geral.

PT



**Filettatura**

Gas conica conforme ISO 7.1, BS 21, DIN 2999.  
Gas cilíndrica conforme ISO 228 Classe A.

IT

**Threads**

Tapered gas in conformity with ISO 7.1, BS 21, DIN 2999.  
Parallel gas in conformity with ISO 228 Class A.

GB

**Gewindearten**

Konisches Gewinde nach Norm ISO 7.1, BS 21, DIN 2999.  
Zylindrisches Gewinde nach Norm ISO 228 Classe A.

DE

**Filetages**

Filetage conique conforme: ISO 7.1, BS 21, DIN 2999.  
Filetage cylindrique conforme: ISO 228 Classe A.

FR

**Roscas**

Gas cónica conforme ISO 7.1, BS 21, DIN 2999.  
Gas cilíndrica conforme ISO 228 Clase A.

ES

**Roscas**

Gas cônica conforme ISO 7.1, BS 21, DIN 2999.  
Gas paralela conforme ISO 228 Classe A.

PT

**2000**

**NIPPLLO CONICO**

NIPPLE (TAPER)

DOPPELNIPPEL KONISCH

MAMELON DOUBLE CONIQUE

MACHÓN CÓNICO

NIPLE COM ROSCA CÔNICA

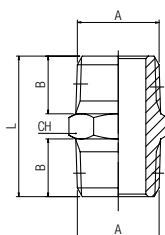

Code	A	B	L	CH	Pack.
02000 00 89 02 00	1/8	7.5	19.5	12	50
02000 00 89 03 00	1/4	11	27	14	50

## 2020

### NIPPOLO DI RIDUZIONE CONICO

REDUCING NIPPLE (TAPER)  
 DOPPELNIPPEL REDUZIERT KONISCH  
 MAMELON DOUBLE INÉGAL, CONIQUE  
 MACHÓN CÓNICO DE REDUCCIÓN  
 NIPLE DE REDUÇÃO COM ROSCA CÓNICA

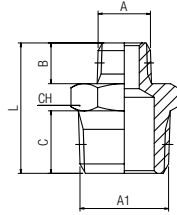

Code	A	A1	B	C	L	CH	Pack.
02020 00 89 AT 00	1/8	1/4	7.5	11	23.5	14	50

## 3000

### MANICOTTO

SLEEVE  
 MUFFE  
 MANCHON  
 MANGUITO  
 LUVA

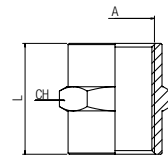

Code	A	L	CH	Pack.
03000 00 89 02 00	1/8	15	14	50
03000 00 89 03 00	1/4	22	17	50

## 4000

### RACCORDO A T FEMMINA

FEMALE TEE  
 T-VERSCHRAUBUNG INNENGEW.  
 TÉ ÉGAL FEMELLE  
 RACOR A T HEMBRA  
 CONEXÃO EM "T" COM ROSCA FÊMEA

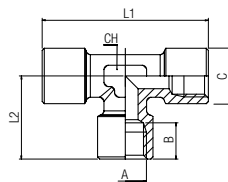

Code	A	B	L2	L1	C	CH	Pack.
04000 00 89 02 00	1/8	8.5	19.5	39	13	12	50
04000 00 89 03 00	1/4	11	24.5	49	16.5	13	25

## 4040

### RACCORDO A T MASCHIO CENTRALE

CENTRE LEG MALE TEE  
 T-VERSCHRAUBUNG AUSSENGEW. MITTIG  
 TÉ ÉGAL FEMELLE, CENTRE MÂLE  
 RACOR A T MACHO CENTRAL  
 CONEXÃO EM "T" COM ROSCA MACHO CENTRAL

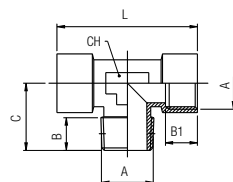

Code	A	B	B1	C	L	CH	Pack.
04040 00 89 02 00	1/8	8	8.5	17.5	39	12	50
04040 00 89 03 00	1/4	11	11	23	49	13	25

## 4050

### RACCORDO A T MASCHIO LATERALE

OFF SET MALE TEE

T-VERSCHRAUBUNG AUSSENGEW. SEITLICH

TÉ ÉGAL FEMELLE, EN BOUT MÂLE

RACOR A T MACHO LATERAL

CONEXÃO EM "T" COM ROSCA MACHO LATERAL

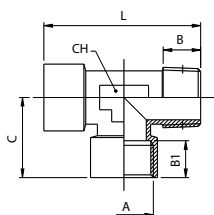

Code	A	B	B1	C	L	CH	Pack.
04050 00 89 02 00	1/8	8	8.5	19.5	37	12	50
04050 00 89 03 00	1/4	11	11	24.5	47.5	13	25

## 5000

### RACCORDO A L MASCHIO

MALE ELBOW

WINKELVERSCHRAUBUNG AUSSENGEW.

EQUERRE MÂLE

RACOR A L MACHO

CONEXÃO EM "L" COM ROSCA MACHO

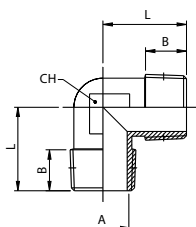

Code	A	B	L	CH	Pack.
05000 00 89 02 00	1/8	7.5	18	11	50
05000 00 89 03 00	1/4	11	24	13	25

## 5010

### RACCORDO A L FEMMINA

FEMALE ELBOW

WINKELVERSCHRAUBUNG INNENGEW.

EQUERRE FEMELLE

RACOR A L HEMBRA

CONEXÃO EM "L" COM ROSCA FÊMEA

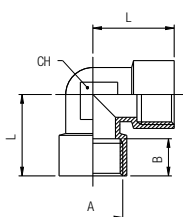

Code	A	B	L	CH	Pack.
05010 00 89 02 00	1/8	8.5	21	11	50
05010 00 89 03 00	1/4	11	25.5	13	25

## 5020

### RACCORDO A L MASCHIO-FEMMINA

MALE-FEMALE ELBOW

WINKELVERSCHRAUBUNG AUSSEN-/INNENGEW.

EQUERRE MÂLE-FEMELLE

RACOR A L MACHO - HEMBRA

CONEXÃO EM "L" MACHO-FÊMEA

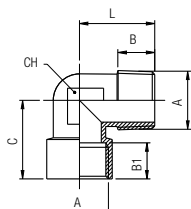

Code	A	B	B1	C	L	CH	Pack.
05020 00 89 02 00	1/8	7.5	8.5	21	18	11	50
05020 00 89 03 00	1/4	11	11	25.5	24	13	25

**ARTICOLI DISPONIBILI A RICHIESTA**

ARTICLES AVAILABLE ON REQUEST  
ARTIKEL ERHÄLTICH AUF ANFRAGE  
ARTICLES DISPONIBLES SUR DEMANDE  
ARTICULOS DISPONIBLES BAJO DEMANDA  
ITENS DISPONÍVEIS SOB ENCOMENDA

**1 SERIE 1000 - CW510L**



**2 SERIE 13000 - CW510L**

