

## Serie Food & Drinks

### Raccordi automatici in PPSU CW510L

PPSU push-in fitting CW510L  
kunststoff steckverschraubungen CW510L  
Raccords instantanés en PPSU CW510L  
Racordaje automático en PPSU CW510L  
Conexões push-in em PPSU CW510L



New

#### Serie 53000

Pag. 5.7

### Raccordi automatici in PPSU INOX 316L

PPSU push-in fitting INOX 316L  
kunststoff steckverschraubungen INOX 316L  
Raccords instantanés en PPSU INOX 316L  
Racordaje automático en PPSU INOX 316L  
Conexões push-in em PPSU INOX 316L



New

#### Serie 53000X

Pag. 5.15

### Raccordi automatici a funzione, valvole a sfera, adattatori

Push-in fittings, function, ball valve, adapters  
Steckverschraubungen, funktionsverschraubungen, magnetventile,  
adapter  
Raccords instantanés, à fonctions, robinets à boisseau sphérique,  
adaptateurs  
Racordaje automático, a funciones, válvulas, accesorios  
Conexões push-in, funcionais válvulas de esfera, acessórios



#### Serie 59000

Pag. 5.24

### Raccordi automatici food grade

Food grade push-in fittings  
Steckverschraubungen lebensmittelkonform  
Raccords instantanés de qualité alimentaire  
Racordaje automático food grade  
Conexões push-in para indústria alimentícia



#### Serie 70000

Pag. 5.44

**RACCORDI AUTOMATICI IN PPSU INOX 316L**

*PPSU PUSH-IN FITTING INOX 316L*

*KUNSTSTOFF STECKVERSCHRAUBUNGEN INOX 316L*

*RACCORDS INSTANTANÉS EN PPSU INOX 316L*

*RACORDAJE AUTOMÁTICO EN PPSU INOX 316L*

*CONEXÕES PUSH-IN EM PPSU INOX 316L*



COMPONENT

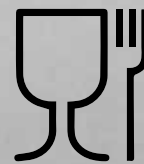

**Serie 5300X**

Aignep con la serie 53000X, nel rispetto della continua evoluzione normativa del settore alimentare, propone una gamma di prodotti certificati NSF 169, nonché alla 1935/2004/CE e DM 174.

I corpi dei raccordi sono realizzati in PPSU che combinano la compatibilità alimentare alla resistenza ad alte temperature fino a +140°C. La parte filettata è realizzata in acciaio INOX AISI 316L. Le guarnizioni sono in FKM alimentare.

### Principali vantaggi

- Certificati NSF 169, 1935/2004/CE, DM 174
- Connessione e sconnessione istantanea
- Pieno passaggio e tenuta al vuoto
- Peso ridotto
- Alternativa economica all'acciaio inox
- Vasta gamma
- Silicon Free

### Applicazioni

- Industria agroalimentare
- Macchine per caffè e vending
- Food & Beverage
- Medicaie
- Vuoto

The 53000X serie is the latest development in the Food&Beverage sector. Fittings are certified to NSF 169 standards and to 1935/2004/CE & Italian DM 174.

The bodies of the fittings are made in PPSU, a material which combines food compatibility and resistance to high temperature up to +140°C. The threads are made in stainless steel AISI 316L. Seals are FKM food-grade.

### Main advantages

- Certified NSF 169, 1935/2004/CE, DM 174
- Quick connection and disconnection
- Full Flow and Vacuum resistant
- Light weight
- Low-cost alternative to stainless steel
- Large range
- Silicon Free

### Applications

- Dairy
- Coffee Machines, Vending
- Food & Beverage
- Medical
- Vacuum

Die Serie 53000 ist unsere neueste Entwicklung für den Bereich Lebensmittel & Getränke. Die Fittings Zertifizierte den Normen NSF 169 und 1935/2004/CE sowie der italienischen Norm DM 174.

Die Körper der Verschraubungen sind aus PPSU, einem Material, das Lebensmittelverträglichkeit und Hochtemperaturbeständigkeit bis +140°C vereint. Die Gewinde sind aus AISI 316L.

Die Dichtungen sind aus lebensmittel geeignetem FKM.

### Hauptvorteile

- Zertifizierte NSF 169, 1935/2004/CE, DM 174
- Schnelles Verbinden und Trennen
- Voller Durchfluss und Vakuum geeignet
- Geringes Gewicht
- Kostengünstige Alternative zu Edelstahl
- Viele Varianten
- Siliziumfrei

### Anwendungen

- Milchprodukte
- Kaffeemaschinen und Automaten
- Lebensmittel & Getränke
- Pharmaindustrie
- Vakuum

La série 53000 est le dernier développement pour le secteur de l'agroalimentaire et la distribution des boissons. Les raccords sont certifiés aux normes NSF 169 et 1935/2004/CE et DM 174 italien.

Les corps des raccords sont réalisés en PPSU, un matériau qui allie compatibilité alimentaire et résistance aux hautes températures jusqu'à +140°C.

Les filetages sont en INOX AISI 316L.

Les joints sont en FKM qualité alimentaire FKM.

### Principaux avantages

- Certifiés NSF 169, 1935/2004/CE, DM 174
- Connexion et déconnexion rapides
- Plein débit et excellente tenue au vide primaire
- Faible poids
- Alternative économique à l'acier inoxydable
- Large gamme
- Sans silicone

### Applications

- Industries agroalimentaire
- Machines à café
- Distributeurs de boisson
- Médical
- Vide

Aignep con la serie 53000, en cumplimiento con la continua evolución de la normativa para industria alimentaria. Ofrece una gama de productos que certificados con la NSF 169, así como con la 1935/2004/CE y el Decreto Ministerial 174.

El cuerpo de los racores está fabricado en PPSU, que combina la compatibilidad alimentaria con la resistencia a altas temperaturas hasta +140°C. La parte roscada esta realizada en acero INOX AISI 316L. Las juntas son de FKM apto para uso alimentario.

### Principales ventajas

- Certificados NSF 169, 1935/2004/CE, DM 174
- Conexión y desconexión instantánea
- Paso completo y sellado al vacío.
- Peso reducido
- Alternativa económica al acero inoxidable
- Amplia gama
- Libre de silicona

### Aplicaciones

- Industria agroalimentaria
- Maquinas de café y vending
- Alimentos y bebidas
- Medical
- Vacío

A Aignep apresenta a série 53000, que atende à continua evolução normativa do setor alimentício.

Esta série apresenta uma gama de itens em certificados com as normas alimentícias NSF 169, 1935/2004/CE e DM 174.

Os corpos das conexões são fabricados em PPSU, que combinam a compatibilidade aos processos alimentícios com a resistência a altas temperaturas, de até +140°C. A parte roscada das conexões é fabricada em aço inoxidável AISI 316L.

As vedações são em FKM alimentício.

### Principais vantagens

- Certificados NSF 169, 1935/2004/CE, DM 174
- Conexão e desconexão instantânea
- Passagem plena e vedação para vácuo
- Peso reduzido
- Alternativa econômica ao aço inox
- Vasta gama de variações
- Silicon Free

### Aplicações

- Aplicações tradicionais
- Máquinas de café, vending machines
- Alimentícia e bebidas
- Médica
- Vácuo



**CARATTERISTICHE TECNICHE**

TECHNICAL CHARACTERISTICS  
 TECHNISCHE ANGABEN  
 CARACTÉRISTIQUES TECHNIQUES  
 CARACTERÍSTICAS TÉCNICAS  
 CARACTERÍSTICAS TÉCNICAS



**Norma di Riferimento**

Reference standard

Entspricht der Norm

Norme de référence

Normativa de referencia

Norma de referència

1907/2006

REACH

2011/65/CE

RoHS

M.O.C.A.

1935/2004

CE

ICIM

COMPLIANT

NSF/ANSI

169

NSF

COMPONENT

ISO

14743:2020

PED

2014/68/UE

SILICON

FREE

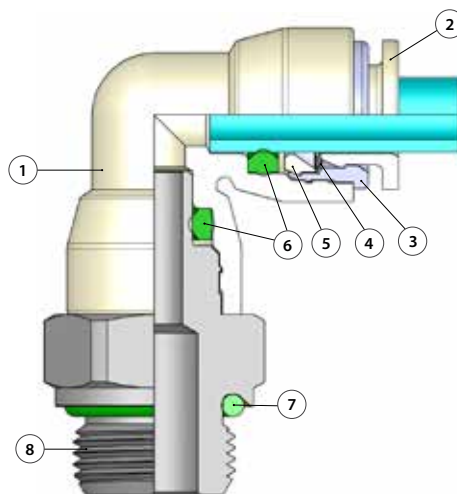

**Materiali e Componenti**

IT

- 1 Corpo in PPSU
- 2 Spintore sgancio tubo PPSU
- 3 Capsula in Acciaio inox AISI 316 L
- 4 Pinza d'aggraffaggio in acciaio inox
- 5 Anello di posizionamento in PPSU
- 6 Guarnizione sagomata in FKM Alimentare
- 7 Guarnizione O-ring FKM Alimentare
- 8 Basetta Filettata in Acciaio inox AISI 316 L

**Component Parts and Materials**

GB

- 1 PPSU Body
- 2 PPSU Collet
- 3 AISI 316 L Steel Capsule
- 4 Steel clamping washer
- 5 Positioning ring PPSU
- 6 Molded seal in FKM FOOD
- 7 O-Ring seal in FKM Food
- 8 Base Threaded AISI 316 L Steel

**Komponenten und Materialien**

DE

- 1 Körper PPSU
- 2 Druckring PPSU
- 3 Haltering Edelstahl AISI 316 L
- 4 Zahnscheibe Edelstahl
- 5 Positionierring PPSU
- 6 Lippendichtung FKM lebensmittelkonform
- 7 O-Ringdichtung FKM lebensmittelkonform
- 8 Gewindebasis Edelstahl AISI 316 L

**Matériaux et Composants**

FR

- 1 Corps: PPSU
- 2 Bouton poussoir: PPSU
- 3 Capsule de retenue: AISI 316 L
- 4 Rondelle d'accrochage en inox
- 5 Anneau de positionnement: PPSU
- 6 Joint de forme en FKM qualité alimentaire
- 7 Joint O-ring FKM qualité alimentaire
- 8 Bague de sécurité: AISI 316 L

**Materiales y componentes**

ES

- 1 Cuerpo en PPSU
- 2 Anillo extracción tubo en PPSU
- 3 Cápsula en Acero inox AISI 316 L
- 4 Pinza de agarre en acero inox
- 5 Anillo de posicionamiento en PPSU
- 6 Junta de forma en FKM alimentario
- 7 Junta tórica en FKM alimentario
- 8 Base roscada en Acero inox AISI 316 L

**Materiais e Componentes**

PT

- 1 Corpo em PPSU
- 2 Anilha de liberação de tubo em PPSU
- 3 Cápsula em Aço inox AISI 316 L
- 4 Pinça de travamento em aço inoxidável
- 5 Anel de posicionamento em PPSU
- 6 Vedação moldada em FKM alimentício
- 7 Vedação o-ring em FKM alimentício
- 8 Base roscada em Aço inox AISI 316 L



**Pressioni**

Pressures

Druckbereich

Pressions

Presiones

Pressões

- 0.99 bar (-0.099 MPa)

20 bar (2.0 MPa) at 20°C



**Temperature**

Temperatures

Temperatur

Températures

Temperaturas

Temperaturas

- 15 °C

+ 140 °C



**Fluidi compatibili**

Aria compressa / Vuoto / Acqua / Alimenti  
 Vapore (Su richiesta in EPDM PX) Max 130°C.

**Fluids**

Compressed air / Vacuum / Water / Food  
 Steam (On request in EPDM PX) Max 130°C.

**Geeignete Medien**

Druckluft / Vakuum / Wasser / Lebensmittel  
 Dampf (Auf Anfrage in EPDM PX) Max 130°C.

**Fluides compatibles**

Air comprimé / Vide / Eau / Boissons  
 Vapeur (Sur demande en EPDM PX) Max 130°C.

**Fluidos compatíveis**

Aire comprimido / Vacío / Agua / Alimentos  
 Vapor (bajo pedido en EPDM PX) Max 130°C.

**Fluidos compatíveis**

Ar comprimido / Vácuo / Água / Alimentos  
 Vapor (A pedido em EPDM PX) Max 130°C.



<b>Tubi di Collegamento</b>	<b>IT</b>	<b>Connection Tubes</b>	<b>GB</b>	<b>Geeignete Rohre</b>	<b>DE</b>
Tubi in materiale plastico: PA6, PA11, PA12, Polietilene, *Poliuretano, PTFE, FEP. *Utilizzo da 90 a 98 Shore, per la massima prestazione è consigliato 98 Shore A.		Plastic tubes: PA6, PA11, PA12, Polyethylene, *Polyurethane, PTFE, FEP. *Use from 90 to 98 Shore, for maximum performance is recommended 98 Shore A.		Kunststoffrohre: PA6, PA11, PA 12, Polyethylene, *Polyurethan, PTFE, FEP. *Verwenden Sie 90 bis 98 Shore, für maximale Leistung wird 98 Shore A empfohlen.	
<b>Tubes Conseillés</b>	<b>FR</b>	<b>Tubos de Conexión</b>	<b>ES</b>	<b>Tubos de Conexão</b>	<b>PT</b>
Tubes plastiques: PA6, PA11, PA12, Polyéthylène, *Polyuréthane, PTFE, FEP. *Utilisation de 90 à 98 Shore, pour une performance maximale recommandée 98 Shore A.		Tubos en material plástico: PA6, PA11, PA 12, Polietileno, *Poliuretano, PTFE, FEP. *Uso de 90 a 98 Shore, para un máximo rendimiento se recomienda 98 Shore A.		Tubos em material plástico: PA6, PA11, PA12, Polietileno, *Poliuretano, PTFE, FEP. *Uso de 90 a 98 Shore, para o desempenho máximo é recomendado 98 Shore A.	



<b>Filettatura</b>	<b>IT</b>	<b>Threads</b>	<b>GB</b>	<b>Gewindearten</b>	<b>DE</b>
Gas cilindrica conforme ISO 228 Classe A.		Parallel gas in conformity with ISO 228 Class A.		Zylindrisches Gewinde nach Norm ISO 228 Classe A.	
<b>Filetages</b>	<b>FR</b>	<b>Roscas</b>	<b>ES</b>	<b>Roscas</b>	<b>PT</b>
Filetage cylindrique conforme: ISO 228 Class A.		Gas cilíndrica conforme ISO 228 Clase A.		Gas paralela conforme ISO 228 Classe A.	



**Coppia di serraggio**

Torque specifications

Angaben Drehmoment

Couple de serrage

Par de apriete

Especificações de Torque

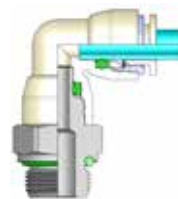

ISO 228

I valori di rottura possono variare in base all'articolo  
 Breaking values may vary according to the item  
 Die maximal werte dienen nur zu informationszwecken  
 Les valeurs maximales sont présentées à titre indicatif  
 Los valores de rotura pueden variar en función del artículo  
 Os valores de ruptura podem variar em função do item

MISURA MEASURE GRÖSSE DIMENSIONS MEDIDA MEDIDA	COPPIA CONSIGLIATA Nm RECOMMENDED TORQUE Nm EMPFOHLENES DREHMOMENT Nm COUPLE DE SERRAGE Nm PAR ACONSEJADO Nm TORQUE RECOMENDADO Nm
1/8	3
1/4	9
3/8	10

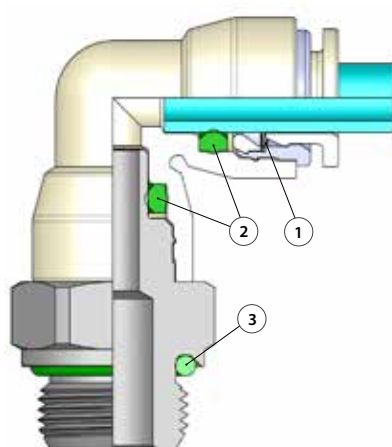
**Vantaggi****IT**

- 1 La pinza in acciaio inox garantisce il perfetto aggraffaggio di tubi di qualsiasi materiale senza danneggiarne la superficie. Il collegamento tra tubo e raccordo assicura una tenuta totale anche in condizioni di urti e vibrazioni.
- 2 La particolare geometria della guarnizione permette inoltre l'utilizzo dei raccordi anche con il vuoto.
- 3 Tutte le filettature di questa serie sono state dotate di elementi di tenuta che permettono l'immediato utilizzo dei raccordi riducendo notevolmente i tempi di installazione.

**Advantages****GB**

- 1 The washer is made in stainless steel ensures the perfect tube clamping with every kinds of materials without damage the surface. The connection between the tube and the fitting ensure a total tightness even in severe conditions such as impact and vibrations.
- 2 The particular geometric shape of the seal ensure the perfect tightness even with vacuum.
- 3 All of threads from this range have been equipped with tightening parts which allow the direct assembly of the fittings, reducing the installation time.

**Vorteile****DE**

- 1 Konisches Gewinde "kurz" Die Zahnscheibe sorgt für eine perfekte Halterung des Rohres ohne die Oberfläche zu beschädigen. Die Dichtheit zwischen Rohr und Verschraubung ist auch bei Erschütterungen und Vibrationen gewährleistet.
- 2 Die besondere Geometrie der Dichtung ermöglicht auch die Anwendung der Verschraubungen in Verbindung mit Vakuum.
- 3 Alle Verschraubungen in dieser Serie sind mit Gewindeabdichtungen ausgestattet, die den sofortigen Einsatz ermöglichen und daher die Montagezeit stark reduzieren.

**Avantages****FR**

- 1 La rondelle en acier inoxydable garantit la parfaite tenue du tube quelle que soit la matière et sans l'endommager. La connexion entre le tube et le raccord assure une étanchéité totale même dans des conditions d'impact ou de vibrations.
- 2 La spécificité géométrique du joint permet l'utilisation des raccords avec le vide.
- 3 Tous les filetages de cette série sont équipés d'éléments d'étanchéité qui permettent l'utilisation immédiate des raccords réduisant ainsi le temps d'installation.

**Ventajas****ES**

- 1 La pinza en acero inoxidable garantiza el perfecto agarre del tubo de cualquier material sin perjudicar la superficie. La conexión entre tubo y raccor asegura una estanqueidad total aun en condiciones de impacto o vibración.
- 2 La particular geometría de la junta garantiza una perfecta estanqueidad incluso en vacío.
- 3 Todas las rosas de esta serie están fabricadas con junta de cierre que permite la inmediata utilización del raccor reduciendo notablemente el tiempo de instalación.

**Vantagens****PT**

- 1 A pinça em aço-inox garante o perfeito travamento do tubo de qualquer material sem danificar a superfície do mesmo. A conexão entre o tubo e a conexão assegura uma vedação total também em condições de impactos e vibrações.
- 2 A geometria particular da vedação permite a utilização da conexão também para aplicações com vácuo.
- 3 Todas as rosas desta série são dotadas de elementos de vedação, o que permite a imediata utilização das conexões, reduzindo notavelmente o tempo de instalação.

## 60020P

### RACCORDO DIRITTO MASCHIO CILINDRICO

STRAIGHT MALE ADAPTOR (PARALLEL)  
 GERADE EINSCHRAUBVERSCHRAUBUNG ZYLINDRISCH  
 RACCORD DROIT MÂLE, CYLINDRIQUE  
 RACOR RECTO MACHO CILÍNDRICO CON TÓRICA  
 CONEXÃO RETA COM ROSCA PARALELA



COMPONENT

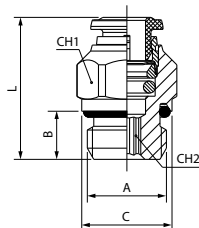

Code	Tube	A	B	C	L	CH1	CH2	Pack.
60020 00 P11	4	M5	3.6	8	20	10	2	50
60020 00 P01	4	1/8	5.4	13	19.5	10	3	50
60020 00 P02	4	1/4	7.1	15	19.5	15	3	50
60020 00 P13	6	M5	3.6	10	23	12	2	50
60020 00 P03	6	1/8	5.4	13	23.5	13	4	50
60020 00 P04	6	1/4	7.1	15	23.5	15	4	50
60020 00 P05	8	1/8	5.4	13	25.5	14	5	50
60020 00 P06	8	1/4	7.1	15	23.5	15	6	50

## 60030P

### RACCORDO DIRITTO FEMMINA

STRAIGHT FEMALE ADAPTOR  
 AUFSCHRAUBVERSCHRAUBUNG  
 RACCORD DROIT, TARAUEE  
 RACOR RECTO HEMBRA  
 CONEXÃO RETA COM ROSCA FÊMEA



COMPONENT

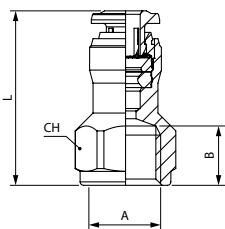

Code	Tube	A	B	L	CH	Pack.
60030 00 P01	4	1/8	8.5	25	13	50
60030 00 P03	6	1/8	8.5	26	13	50
60030 00 P04	6	1/4	11	29.5	16	50
60030 00 P05	8	1/8	8.5	27	15	50
60030 00 P06	8	1/4	11	29.5	17	50

## 53040X

### RACCORDO DIRITTO INTERMEDIO

STRAIGHT CONNECTOR  
 VERBINDUNGSVERSCHRAUBUNG  
 RACCORD UNION DOUBLE  
 RACOR RECTO INTERMEDIO  
 CONEXÃO RETA TUBO-TUBO



COMPONENT

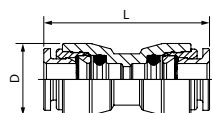

Code	Tube	D	L	Pack.
53040 X0 002	4	11.5	29.5	50
53040 X0 004	6	14	32	50
53040 X0 005	8	16	34.5	50

## 53117X

### RACCORDO A L ORIENTABILE MASCHIO CILINDRICO

ORIENTING ELBOW MALE ADAPTOR (PARALLEL)  
 WINKELVERSCHRAUBUNG ZYLINDRISCH (DREHBAR)  
 EQUERRE ORIENTABLE MÂLE, CYLINDRIQUE  
 RACOR A L ORIENTABLE MACHO CILÍNDRICO CON TÓRICA  
 CONEXÃO MACHO EM "L" ORIENTÁVEL COM ROSCA PARALELA

New

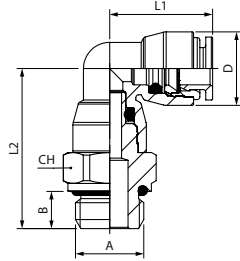

Code	Tube	A	B	L1	L2	CH	D	Pack.
53117 X0 002	4	M5	4	15.7	15	8	11.5	50
53117 X0 004	4	1/8	6	17.2	26	13	11.5	50
53117 X0 005	4	1/4	8	17.2	28.5	15	11.5	50
53117 X0 011	6	M5	4	18.6	15	8	14	50
53117 X0 013	6	1/8	6	19.6	29	13	14	50
53117 X0 014	6	1/4	8	19.6	31	15	14	50
53117 X0 018	8	1/4	8	21.3	33	15	16	50
53117 X0 019	8	3/8	9	21.3	35	20	16	50

## 53130X

### RACCORDO A L INTERMEDIO

ELBOW CONNECTOR  
 WINKELVERSCHRAUBUNG  
 RACCORD EQUERRE  
 RACOR A L INTERMEDIO  
 CONEXÃO EM "L" TUBO-TUBO

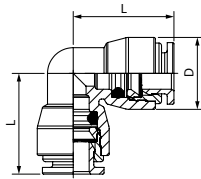

Code	Tube	D	L	Pack.
53130 X0 002	4	11.5	17	50
53130 X0 004	6	14	19.5	50
53130 X0 005	8	16	21.5	50

## 53217X

### RACCORDO A T ORIENTABILE MASCHIO CILINDRICO

ORIENTING TEE MALE ADAPTOR (PARALLEL)  
 T-EINSCHRAUBVERSCHRAUBUNG ZYLINDRISCH (DREHBAR)  
 TÉ ORIENTABLE MÂLE, CYLINDRIQUE  
 RACOR A T ORIENTABLE MACHO CILÍNDRICO CON TÓRICA  
 CONEXÃO MACHO EM "T" ORIENTÁVEL COM ROSCA PARALELA

New

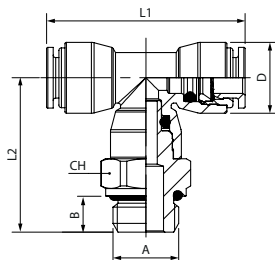

Code	Tube	A	B	L1	L2	CH	D	Pack.
53217 X0 004	4	1/8	6	34.4	26	13	11.5	50
53217 X0 005	4	1/4	8	34.4	28.5	15	11.5	50
53217 X0 013	6	1/8	6	39.2	29	13	14	50
53217 X0 014	6	1/4	8	39.2	31	15	14	50
53217 X0 018	8	1/4	8	42.6	33	15	16	50
53217 X0 019	8	3/8	9	42.6	35	20	16	50

## 53230X

### RACCORDO A T INTERMEDIO

TEE CONNECTOR  
T-ANSCHLUSS  
RACCORD TÉ  
RACOR A T INTERMEDIO  
CONEXÃO EM "T" TUBO-TUBO

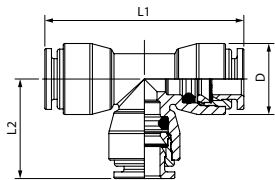

Code	Tube	L1	L2	D	Pack.
53230 X0 002	4	34.5	17	11.5	50
53230 X0 004	6	39	19.5	14	50
53230 X0 005	8	42.5	21.5	16	50

## 60600

### ADATTATORE MASCHIO CILINDRICO

MALE ADAPTOR PARALLEL  
EINSCHRAUBSTECKVERSCHRAUBUNG ZYLINDRISCH  
ADAPTATEUR ENCLIQUETABLE MÂLE, CYLINDRIQUE  
ADAPTADOR MACHO CILINDRICO  
ADAPTADOR COM ROSCA MACHO PARALELA

New

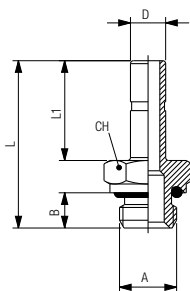

Code	D	A	B	L	L1	CH	Pack.
60600 00 007	6	1/8	6	28.5	17	13	5
60600 00 010	8	1/4	8	31.5	18	16	5
60600 00 011	8	3/8	9	33.5	18	20	5

## 60700

### RIDUZIONE

REDUCER  
REDUZIERUNG  
RÉDUCTION ENCLIQUETABLE  
REDUCCIÓN  
REDUÇÃO

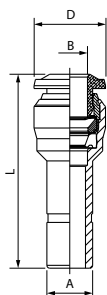

Code	A	B	L	D	Pack.
60700 00 002	6	4	30.5	10.5	5
60700 00 003	8	4	33	10.5	5
60700 00 004	8	6	34	12.5	5

**50990****LEVA SGANCIO ADATTATORI**

TOOL FOR DISASSEMBLING

LÖSEWERKZEUG

OUTIL DE DÉMONTAGE

LLAVE DE DESMONTAJE

FERRAMENTA PARA DESMONTAGEM

Code

**50990 00 001**

Pack.

10

