















**Prese ad Innesto Rapido** - Quick Couplings - Schnellverschluss Kupplungen - Coupleurs Automatiques - Enchufes Rápidos - Conexões de Engate Rápido

<p>SERIE UNI ISO 6150 A-6</p>  <p><b>Serie 100</b> Pag. 15.7 - 15.10</p>	<p>SERIE MIGNON <b>New</b></p>  <p><b>Serie 110</b> Pag. 15.11 - 15.16</p>	<p>SERIE UNI ISO 6150 B-12</p>  <p><b>Serie 120</b> Pag. 15.17 - 15.22</p>	<p>ITALIAN PROFILE</p>  <p><b>Serie 120</b> Pag. 15.23 - 15.28</p>
<p>SERIE UNI ISO 6150 B-15</p>  <p><b>Serie 130</b> Pag. 15.29 - 15.33</p>	<p><b>Serie 140</b> Pag. 15.34 - 15.39</p>	<p>EUROPEAN PROFILE</p>  <p><b>Serie 160</b> Pag. 15.40 - 15.45</p>	<p>SWISS PROFILE</p>  <p><b>Serie 170</b> Pag. 15.46 - 15.50</p>
<p>MIGNON PROFILE <b>New</b></p>  <p><b>Serie 180</b> Pag. 15.51 - 15.54</p>	<p>MULTISOCKET <b>New</b></p>  <p><b>Serie 190 - 63190</b> Pag. 15.55 - 15.61</p>	<p>JAPANESE PROFILE</p>  <p><b>Serie 400</b> Pag. 15.62 - 15.64</p>	<p><b>Serie 700</b> Pag. 15.65 - 15.67</p>
<p>SERIE UNI ISO 6150 B-17</p>  <p><b>Serie 710</b> Pag. 15.68 - 15.70</p>	<p>B-SOCKET EUROPEAN</p>  <p><b>Serie 720</b> Pag. 15.71 - 15.74</p>	<p>EUROPEAN PROFILE <b>New</b></p>  <p><b>Serie 730</b> Pag. 15.75 - 15.80</p>	<p>EUROPEAN PROFILE <b>New</b></p>  <p><b>Serie 740</b> Pag. 15.81 - 15.83</p>

**Prese di Sicurezza ad Innesto Rapido** - Safety Quick Couplings - Kupplungen Sicherheit - Coupleurs de Sécurité - Enchufes de Seguridad - Conexões de Segurança

<p>SERIE UNI ISO 6150 B-12</p>  <p><b>Serie 620</b> Pag. 15.85 - 15.88</p>	<p>ITALIAN PROFILE</p>  <p><b>Serie 650</b> Pag. 15.89 - 15.90</p>	<p>EUROPEAN PROFILE</p>  <p><b>Serie 660</b> Pag. 15.91 - 15.92</p>	<p>SWISS PROFILE</p>  <p><b>Serie 670</b> Pag. 15.93 - 15.94</p>
<p>SERIE UNI ISO 6150 B-12</p>  <p><b>Serie 0B120</b> Pag. 15.97 - 15.99</p>	<p>SERIE UNI ISO 6150 C-10</p>  <p><b>Serie 0B140</b> Pag. 15.100 - 15.102</p>	<p>EUROPEAN PROFILE <b>New</b></p>  <p><b>Serie 0B160</b> Pag. 15.103 - 15.105</p>	

**Giunti ad Innesto Rapido per Raffreddamento Stampi** - Quick Couplings for Molding Cooling - Schnellkupplungen für Spritzgussanwendungen - Coupleurs pour Moulés D'injection - Enchufes Rápidos para Refrigeración de Moldes - Conexões de Engate Rápido para Resfriamento de Moldes

<p>FRENCH PROFILE DN 8 - DN 12</p>  <p><b>Series 410 - 420 - 510 - 520</b> Pag. 15.104 - 15.110</p>	<p>INTERNATIONAL PROFILE DN 6 - DN 9</p>  <p><b>Series 430 - 440 - 530 - 540</b> Pag. 15.112 - 15.119</p>	<p>EUROPEAN PROFILE DN 6 - DN 9</p>  <p><b>Series 460 - 470 - 560 - 570</b> Pag. 15.120 - 15.127</p>	<p><b>6049</b> Pag. 15.128</p> 
--	--	--	--

**Pistole di Soffiaggio** - Blow Guns - Blaspistolen - Soufflettes - Pistolas Sopladoras - Pistola de Ar

 <p><b>Series 360</b> Pag. 15.130 - 15.132</p>	 <p><b>Series 300</b> Pag. 15.133 - 15.135</p>	 <p><b>Spare Parts</b> Pag. 15.136</p>	 <p><b>Series 340</b> Pag. 15.137</p>
---	---	--	--

Alignep si riserva il diritto di variare modelli e ingombri senza preavviso - Alignep reserves the right to vary models and dimensions without notice - Alignep behält sich das Recht vor, Daten ohne Ankündigung zu ändern  
 Alignep se reserva el derecho de modificar modelos y dimensiones sin previo aviso - Alignep se réserve le droit de modifier les données sans préavis

**SERIE 140** UNI ISO 6150 C-10



**CARATTERISTICHE TECNICHE**  
 TECHNICAL CHARACTERISTICS  
 TECHNISCHE ANGABEN  
 CARACTÉRISTIQUES TECHNIQUES  
 CARACTERÍSTICAS TÉCNICAS  
 CARACTERÍSTICAS TÉCNICAS



**Norma di Riferimento**  
 Reference standard  
 Entspricht der Norm  
 Norme de référence  
 Normativa de referencia  
 Norma de referència

1907/2006 <b>REACH</b> ✓	2011/65/CE <b>RoHS</b> ✓
PED 2014/68/UE	SILICON FREE

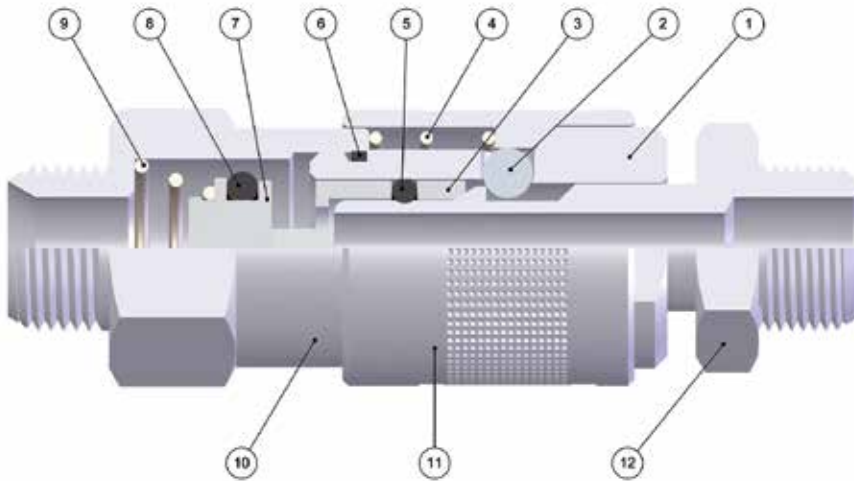

**FKM A RICHIESTA**  
 IF REQUESTED FKM  
 FKM AUF ANFRAGE  
 FKM SUR DEMANDE  
 FKM BAJO DEMANDA  
 FKM SOB ENCOMENDA

DN  
5.5 mm

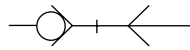

UNI ISO 6150 C-10

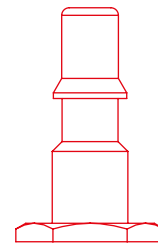

1:1

Materiali e Componenti	IT	Component Parts and Materials	GB	Komponenten und Materialien	DE
1 Corpo in Ottone Nichelato		1 Nickel-Plated Brass Body		1 Körper Messing Vernickelt	
2 Sfera in Acciaio AISI 420		2 Stainless Steel AISI 420 Balls		2 Kugel Edelstahl AISI 420	
3 Anello Guida Innesto in Ottone Nichelato		3 Nickel-Plated Brass Guide Ring Coupling		3 Stecker Führungsring Messing Vernickelt	
4 Molla Ghiera in Acciaio AISI 302		4 Stainless Steel AISI 302 Ring Nut Spring		4 Entriegelungsfeder Edelstahl AISI 302	
5 Guarnizione O-Ring in NBR		5 NBR O-Ring Seals		5 O-Ring NBR	
6 Guarnizione O-Ring in NBR		6 NBR O-Ring Seals		6 O-Ring NBR	
7 Otturatore in Ottone Nichelato		7 Nickel-Plated Brass Shutter		7 Verschluss Messing Vernickelt	
8 Guarnizione O-Ring in NBR		8 NBR O-Ring Seals		8 O-Ring NBR	
9 Molla Otturatore in Acciaio AISI 302		9 Stainless Steel AISI 302 Shutter Spring		9 Verschlussfeder Edelstahl AISI 302	
10 Attacco Terminale in Ottone Nichelato		10 Nickel-Plated Brass Coupling Back Part		10 Einschraubkörper Messing Vernickelt	
11 Ghiera in Ottone Nichelato		11 Nickel-Plated Brass Sleeve		11 Entriegelungshülse Messing Vernickelt	
12 Innesto in Ottone Nichelato		12 Nickel-Plated Brass Plug Outline		12 Stecker Messing Vernickelt	
Matériaux et Composants	FR	Materiales y Componentes	ES	Materiali e Componentes	PT
1 Corps: Laiton Nickelé		1 Cuerpo en latón niquelado		1 Corpo em Latão Niquelado	
2 Bille: Acier Inoxydable AISI 420		2 Esfera en acero AISI 420		2 Esfera em aço AISI 420	
3 Bague de Guidage: Laiton Nickelé		3 Anillo guía enchufe en latón niquelado		3 Anel guia do plug em latão niquelado	
4 Ressort de Bague: Acier Inoxydable AISI 302		4 Muelle tuerca en acero AISI 302		4 Mola da porca em aço AISI 302	
5 Joint Torique en NBR		5 Junta tórica en NBR		5 Vedação O-Ring em NBR	
6 Joint Torique en NBR		6 Junta tórica en NBR		6 Vedação O-Ring em NBR	
7 Clapet: Laiton Nickelé		7 Obturador en latón niquelado		7 Obturador em latão niquelado	
8 Joint Torique en NBR		8 Junta tórica en NBR		8 Vedação O-Ring em NBR	
9 Ressort de Clapet: Acier Inoxydable AISI 302		9 Muelle obturador en acero AISI 302		9 Mola do obturador em aço AISI 302	
10 Corps: Laiton Nickelé		10 Terminal de conexión en latón niquelado		10 Conexão terminal em latão niquelado	
11 Bague: Laiton Nickelé		11 Tuerca en latón niquelado		11 Porca em latão niquelado	
12 Embout: Laiton Nickelé		12 Enchufe en latón niquelado		12 Plug em latão niquelado	



**Pressione d'esercizio**

Working Pressures  
Betriebsdruck  
Pression de service  
Presión de Ejercicio  
Pressão de Trabalho

**0 bar**  
**25 bar**



**Max pressione statica (no pulsazioni)**

Maximum static pressure (no pulsations)  
Maximaler statischer Betriebsdruck (ohne pulsations)  
Pression statique maximale (sans pulsation)  
Presión estática máxima (sin pulsaciones)  
Pressão estática máxima (sem pulsações)

**35 bar**



**Temperature**

Temperatures  
Temperatur  
Températures  
Temperaturas  
Temperaturas

**- 20 °C**  
**+ 80 °C**

Con O-ring in FKM  
With FKM O-ring  
Mit O-ring in FKM  
Avec joints en FKM  
Con junta tórica en FKM  
Com O-ring em FKM

**- 10 °C**  
**+ 200 °C**



**Fluidi compatibili**

Aria compressa

Fluids  
Compressed air

Geeignete Medien  
Druckluft

Fluides compatibles  
Air comprimé

Fluidos compatibles  
Aire comprimido

Fluidos compatíveis  
Ar comprimido

Per altri fluidi, consultare l'ufficio tecnico Aignep.  
For other fluids, consult the technical department Aignep.  
Für andere Flüssigkeiten, kontaktieren Sie uns.  
Pour d'autres fluides, veuillez nous consulter.  
Para otros fluidos póngase en contacto con el departamento técnico Aignep.  
Para outros fluidos consulte o departamento técnico da Aignep.



**Portata**

NI/min

Flow Rate  
Durchflusswerte  
Débit  
Caudal de Flujo  
Vazão

6 bar Δ 1	6 bar Δ 0.5	6 bar *
1160	900	1550

\* Scarico libero - Exhaust Free - Kostenlose Auspuff - Échappement libre - Escape Libre - Descarga livre.



**Filettatura**

IT

Gas cilindrica conforme ISO 228 Classe A.

**Threads**

GB

Parallel gas in conformity with ISO 228 Class A.

**Gewindearten**

DE

Zylindrisches Gewinde nach Norm ISO 228 Classe A.

**Filetages**

FR

Filetage cylindrique conforme: ISO 228 Class A.

**Roscas**

ES

Gas cilindrica conforme ISO 228 Clase A.

**Roscas**

PT

Gas paralela conforme ISO 228 Classe A.

# 141

## PRESA MASCHIO

MALE SOCKET  
 VERSCHLUSS-KUPPLUNG MIT AUSSENGEWINDE  
 COUPLEUR MÂLE  
 ENCHUFE MACHO  
 SOQUETE COM ROSCA MACHO

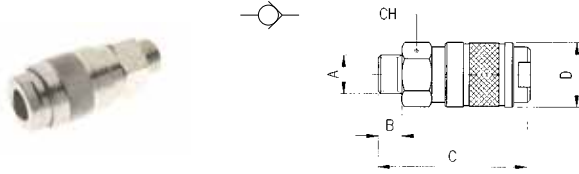

Code	A	B	C	D	CH	Pack.
00141 00 001	1/4	8	51	22	19	10
00141 00 002	3/8	9	52	22	19	10
00141 00 003	1/2	10	52.5	22	24	10

# 142

## PRESA FEMMINA

FEMALE SOCKET  
 VERSCHLUSS-KUPPLUNG MIT INNENGEWINDE  
 COUPLEUR FEMELLE  
 ENCHUFE HEMBRA  
 SOQUETE COM ROSCA FÊMEA

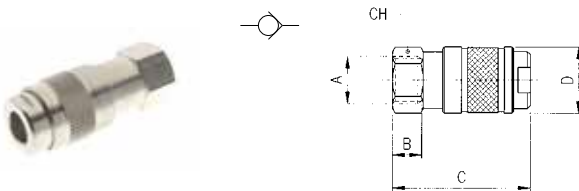

Code	A	B	C	D	CH	Pack.
00142 00 001	1/4	11	53	22	19	10
00142 00 002	3/8	11.5	53.5	22	20	10
00142 00 003	1/2	14	56	22	24	10

# 143

## PRESA A CALZAMENTO CON MOLLA

COMPRESSION SOCKET WITH SPRING  
 VERSCHLUSS-KUPPLUNG MIT KNICKSCHUTZFEDER  
 COUPLEUR AVEC RESSORT DE PROTECTION  
 ENCHUFE TUBO CON MUELLE  
 SOQUETE COM CONEXÃO PUSH-ON COM MOLLA

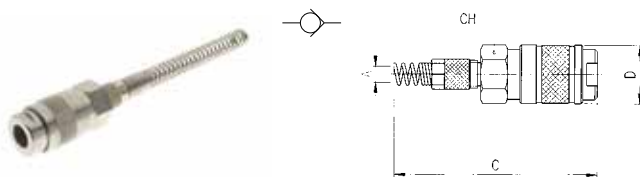

Code	A	C	D	CH	Pack.
00143 00 001	6/4	136	22	19	10
00143 00 002	8/6	141.5	22	19	10
00143 00 003	10/8	148	22	19	10

Molla Acciaio Inox AISI 304 - EN 1.4301  
 Stainless Steel Spring AISI 304 - EN 1.4301  
 Edelstahlfeder AISI 304 - EN 1.4301  
 Ressort Acier Inoxydable AISI 304 - EN 1.4301  
 Muelle Acero Inoxidable AISI 304 - EN 1.4301  
 Mola Aço Inoxidável AISI 304 - EN 1.4301

# 144

## PRESA A CALZAMENTO

COMPRESSION SOCKET  
 VERSCHLUSS-KUPPLUNG MIT ÜBERWURFVERSCHRAUBUNG  
 COUPLEUR RACCORD À COIFFE  
 ENCHUFE TUBO  
 SOQUETE COM CONEXÃO PUSH-ON

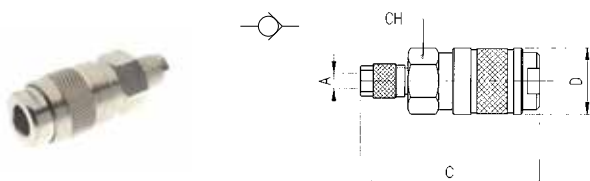

Code	A	C	D	CH	Pack.
00144 00 001	6/4	54	22	19	10
00144 00 002	8/6	54	22	19	10
00144 00 003	10/8	54	22	19	10

## 145

### PRESA CON PORTAGOMMA A RESCA

BARBED SOCKET  
 VERSCHLUSS-KUPPLUNG MIT SCHLAUCHTÜLLE  
 COUPLEUR À DOUILLE ANNELÉE POUR TUBE  
 ENCHUFE ESPIGA  
 SOQUETE COM ESPIGÃO PARA MANGUEIRA DE BORRACHA

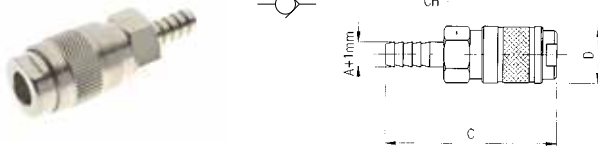

Code	A	C	D	CH	Pack.
00145 00 001	6	62.5	22	19	10
00145 00 002	8	62.5	22	19	10
00145 00 003	10	62.5	22	19	10
00145 00 004	12	62.5	22	19	10

## 241

### INNESTO MASCHIO

MALE PLUG  
 STECKER MIT AUSSENGEWINDE  
 EMBOUT MÂLE  
 ADAPTADOR MACHO  
 PLUG COM ROSCA MACHO

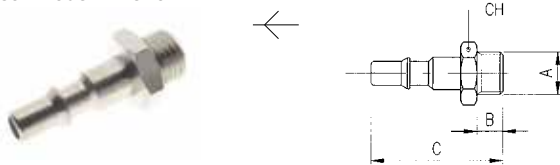

Code	A	B	C	CH	Pack.
00241 00 01 03 NB	1/4	8	41.5	17	10
00241 00 01 04 NB	3/8	9	42.5	19	10
00241 00 01 05 NB	1/2	10	44	24	10

## 241AC

### INNESTO IN ACCIAIO MASCHIO

STEEL MALE PLUG  
 STECKER MIT AUSSENGEWINDE AUS STAHL  
 EMBOUT MÂLE EN ACIER  
 ADAPTADOR EN ACERO MACHO  
 PLUG EM AÇO COM ROSCA MACHO

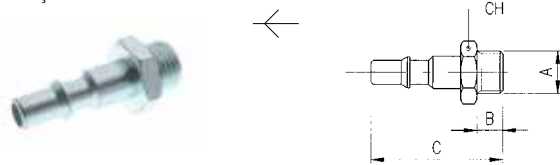

Code	A	B	C	CH	Pack.
241AC 00 51 03 ZI	1/4	8	41.5	17	10
241AC 00 51 04 ZI	3/8	9	42.5	19	10
241AC 00 51 05 ZI	1/2	10	44	24	10

Acciaio Indurito  
 Hardened Steel  
 Gehärtetem Stahl  
 Acier Trempé  
 Acero Curtido  
 Aço Endurecido

## 242

### INNESTO FEMMINA

FEMALE PLUG  
 STECKER MIT INNENGEWINDE  
 EMBOUT FEMELLE  
 ADAPTADOR HEMBRA  
 PLUG COM ROSCA FÊMEA

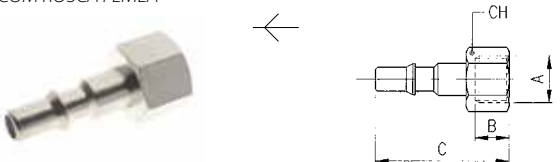

Code	A	B	C	CH	Pack.
00242 00 01 03 NB	1/4	11	41.5	17	10
00242 00 01 04 NB	3/8	11.5	42	19	10
00242 00 01 05 NB	1/2	14	44.5	24	10

## 242AC

### INNESTO IN ACCIAIO FEMMINA

STEEL FEMALE PLUG  
 STECKER MIT INNENGEWINDE AUS STAHL  
 EMBOUT FEMELLE EN ACIER  
 ADAPTADOR EN ACERO HEMBRA  
 PLUG EM AÇO COM ROSCA FÊMEA

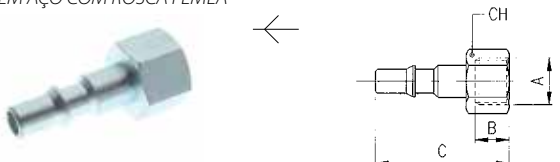

Code	A	B	C	CH	Pack.
242AC 00 51 03 ZI	1/4	11	41.5	17	10
242AC 00 51 04 ZI	3/8	11.5	42	19	10
242AC 00 51 05 ZI	1/2	14	44.5	24	10

Acciaio Indurito  
 Hardened Steel  
 Gehärtetem Stahl  
 Acier Trempé  
 Acero Curtido  
 Aço Endurecido

## 243

### INNESTO A CALZAMENTO CON MOLLA

COMPRESSION PLUG WITH SPRING  
 STECKER MIT KNICKSCHUTZFEDER  
 EMBOUT AVEC RESSORT DE PROTECTION  
 ADAPTADOR TUBO CON MUELLE  
 PLUG COM CONEXÃO PUSH-ON COM MOLA



Code	A	C	CH	Pack.
00243 00 001	6/4	128	12	10
00243 00 002	8/6	133.5	13	10
00243 00 003	10/8	140	14	10

Molla Acciaio Inox AISI 304 - EN 1.4301  
 Stainless Steel Spring AISI 304 - EN 1.4301  
 Edelstahlfeder AISI 304 - EN 1.4301  
 Ressort Acier Inoxydable AISI 304 - EN 1.4301  
 Muelle Acero Inoxidable AISI 304 - EN 1.4301  
 Mola Aço Inoxidável AISI 304 - EN 1.4301

## 244

### INNESTO A CALZAMENTO

COMPRESSION PLUG  
 STECKER MIT ÜBERWURFVERSCHRÄUBUNG  
 EMBOUT À RACCORD À COIFFE  
 ADAPTADOR TUBO  
 PLUG COM CONEXÃO PUSH-ON

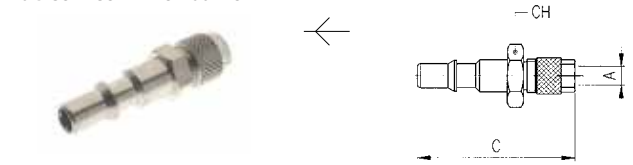

Code	A	C	CH	Pack.
00244 00 001	6/4	46	12	10
00244 00 002	8/6	46	13	10
00244 00 003	10/8	48	14	10

## 245

### INNESTO CON PORTAGOMMA A RESCA

BARBED PLUG  
 STECKER MIT SCHLAUCHTÜLLE  
 EMBOUT À DOUILLE ANNELÉE POUR TUBE  
 ADAPTADOR ESPIGA  
 PLUG COM ESPIGÃO PARA TUBO DE BORRACHA



Code	A	C	D	Pack.
00245 00 01 X4 NB	6	48	10	10
00245 00 01 X7 NB	8	51	12	10
00245 00 01 X9 NB	10	51	14	10
00245 00 01 Y1 NB	12	51	16	10

## 245AC

### INNESTO IN ACCIAIO CON PORTAGOMMA A RESCA

STEEL BARBED PLUG  
 STECKER MIT SCHLAUCHTÜLLE AUS STAHL  
 EMBOUT À DOUILLE ANNELÉE POUR TUBE EN ACIER  
 ADAPTADOR EN ACERO ESPIGA  
 PLUG EM AÇO COM ESPIGÃO PARA TUBO DE BORRACHA

New

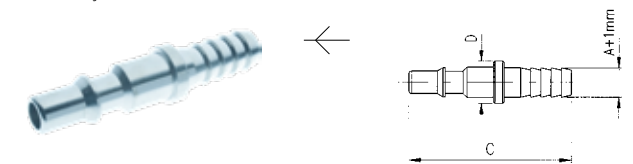

Code	A	C	D	Pack.
245AC 00 51 X4 ZI	6	48	10	10
245AC 00 51 X7 ZI	8	51	12	10
245AC 00 51 X9 ZI	10	51	14	10
245AC 00 51 Y1 ZI	12	51	16	10

Acciaio Indurito  
 Hardened Steel  
 Gehärtetem Stahl  
 Acier Trempé  
 Acero Curtido  
 Aço Endurecido

## 247

### INNESTO A BAIONETTA

BAYONET PLUG  
 STECKER MIT BAJONETT-VERSCHLUSS  
 EMBOUT À BAIONETTE  
 ADAPTADOR BAYONETA  
 PLUG COM CONEXÃO TIPO BAIONETA

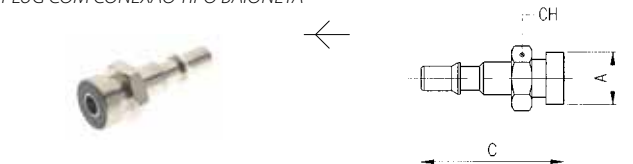

Code	A	C	CH	Pack.
00247 00 001	15	42	15	10

# 248

## INNESTO A SCARICO PROGRESSIVO

PLUG WITH GRADUAL EXHAUST  
 STECKER MIT PROGRESSIVER ENTLASTUNG  
 EMBOUT À PASSAGE PROGRESSIF  
 ADAPTADOR DE DESCARGA PROGRESIVA  
 PLUG COM ESCAPE PROGRESSIVO

Code	A	B	C	CH	Pack.
00248 00 001	1/4	11	50	17	10

